

## Synthesis of new aryl substituted 5-alkylidenefuran-2(5H)-ones

Ruonan Zhang, Daniel Chan, Shari Jessica, George Iskander, David StC Black, and Naresh Kumar\*

School of Chemistry, University of New South Wales, UNSW, Sydney, NSW 2052, Australia

E-mail: [n.kumar@unsw.edu.au](mailto:n.kumar@unsw.edu.au)

Dedicated to Professor Ted Sorenson

---

### Abstract

The rapid emergence of bacterial resistance in recent years has demanded the development of new drugs and therapies with novel modes of action to supplement existing antibiotics. Brominated furanones or fimbrolides are a promising class of quorum sensing inhibitors that inhibit biofilm formation and the expression of virulence in *in vitro* and *in vivo* models. We report here an efficient synthesis of novel brominated 5-alkylidenefuran-2(5H)-ones, making use of  $\gamma$ -oxo- $\alpha,\beta$ -dibromoalkanoic acid **7** as the key intermediate. Brominated furanones were subjected to the Suzuki-Miyaura cross-coupling reaction to generate a library of novel aryl furanones. This methodology may be readily adapted to the synthesis of a wide variety of substituted furanones.

**Keywords:** Furanones, 5-alkylidenefuranones, anti-bacterial, Suzuki-Miyaura reaction, dibromoalkanoic acids, alkenoic acids

---

### Introduction

The emergence of multi-resistant strains of bacteria in recent years has driven the search for new therapeutic compounds with novel modes of action to supplement existing anti-microbials.<sup>1</sup> Traditional antibiotics impose selective pressure on bacteria, leading to drug resistance.<sup>2</sup> A new key strategy is to target the various regulatory systems in bacteria that control the expression of virulence.

Bacteria communicate with each other *via* small intercellular signal compounds and this regulatory system is known as quorum sensing (QS).<sup>3,4</sup> Quorum sensing is critical for bacterial biofilm formation and the expression of virulent phenotypes. *N*-Acyl-L-homoserine lactones (AHL) are the most widely studied class of QS mediators and they are used by many pathogenic Gram-negative bacterial species.<sup>5</sup>

Natural furanones **1** isolated from the red alga *Delisea pulchra* were found to possess significant QS inhibitor activity (Figure 1).<sup>6</sup> They share a common 4-halo-3-butyl-5-halomethylenefuran-2(5H)-one skeleton but vary in the number and nature of the halogen substituents and the presence or absence of oxygen functionality in the butyl side-chain. These halogenated furanones or “fimbrolides” inhibit biofilm formation by specifically interfering with AHL-mediated quorum sensing. Importantly, the expression of the virulent phenotypes was inhibited at non-bactericidal concentrations.<sup>7-10</sup> Therefore, these furanones should not impose the same selective pressure as conventional antibiotics on bacterial strains to develop resistance. To date over 200 analogues of furanones with different bromination patterns and alkyl chain lengths have been generated and evaluated for QS inhibitor activities.<sup>11</sup>

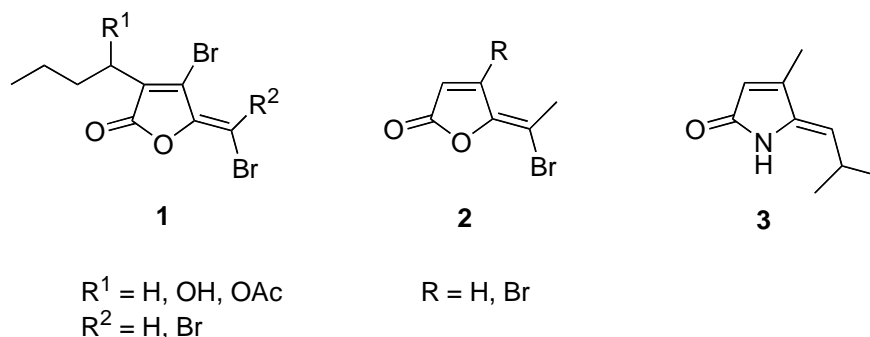

**Figure 1.** Natural fimbrolides **1** from *D. pulchra*, synthetic fimbrolides **2** and pulchellalactam **3**.

Studies have shown that simple fimbrolides **2** lacking the C3-butyl still show significant QS inhibitor activity.<sup>8,10</sup> Synthetic fimbrolide **2** (R = Br) was found to reduce *P. aeruginosa* levels in the lungs by three orders of magnitude in a pulmonary mouse model.<sup>9</sup>

Intrigued by the exocyclic *iso*-propyl moiety in the structurally related natural product pulchellalactam<sup>12</sup> **3** as well as the presence of the similar *tert*-butyl group in various antibacterial compounds,<sup>13,14</sup> we set out to synthesize brominated furanones **4** (R<sup>1</sup> or R<sup>2</sup> = Br) carrying a vinylic *iso*-propyl or *tert*-butyl substituent at the C5 position (Figure 2). Compounds where the C4-bromine was switched to the C3 position were also targeted to afford a more comprehensive library of furanones for structure-function investigations.

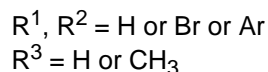
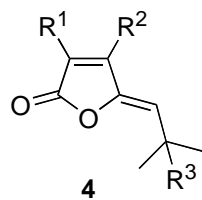
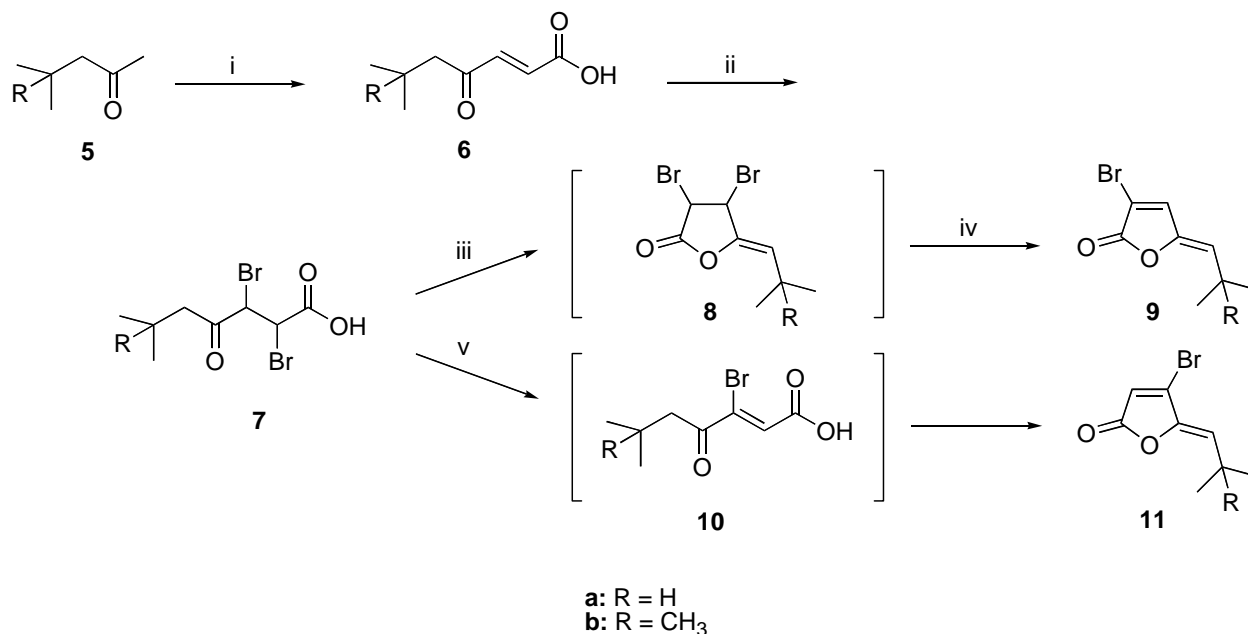

**Figure 2.** Targeted furanones **4**.

We also envisaged that these brominated furanones could be utilized as synthetic intermediates in the Suzuki-Miyaura cross-coupling reaction.<sup>15</sup> 3-Aryl- and 4-arylfuran-2(5*H*)-one cores are widely distributed in natural products and biologically active compounds.<sup>16,17</sup> Consequently, the synthesis of novel 3- and 4-aryl-5-alkylidenefuranones **4** ( $R^1$  or  $R^2 = \text{Ar}$ ) was of interest to us.

## Results and Discussion

A variety of methods have been reported in the literature for the synthesis of fimbrolides and their analogues.<sup>11</sup> However, most approaches tended to be unwieldy and required many steps in the synthetic sequence. The most facile synthesis of our targeted fimbrolides used a methodology developed by our group involving the key intermediate  $\gamma$ -oxo- $\alpha,\beta$ -dibromoalkanoic acid **7** (Scheme 1).<sup>18</sup> Unbranched alkanones related to compounds **5** undergo reaction with glyoxylic acid at the methylene rather than the methyl group adjacent to the carbonyl: however, alkanones **5** react regioselectively at the methyl group.



**Scheme 1.** Reagent and conditions: (i) HCOCOOH (1.6 equiv), H<sub>3</sub>PO<sub>4</sub>, 75 °C, 5 h (**6a**: 60%, **6b**: 40%); (ii) Br<sub>2</sub> (0.9 equiv), CH<sub>2</sub>Cl<sub>2</sub>, -78 °C, 3 h (**7a**: 78%, **7b**: 89%); (iii) P<sub>2</sub>O<sub>5</sub>, CH<sub>2</sub>Cl<sub>2</sub>, reflux, 1 h; (iv) DBU (1.1 equiv), CH<sub>2</sub>Cl<sub>2</sub>, -78 °C, 1 h (**9a**: 63%, **9b**: 75%); (v) H<sub>2</sub>SO<sub>4</sub>, CH<sub>2</sub>Cl<sub>2</sub>, 100 °C, reflux (**11a**: 54%, **11b**: 25%).

The first step involved the regioselective condensation of alkanones **5** with glyoxylic acid. The <sup>1</sup>H NMR spectrum of the alkenoic acid **6a** revealed two doublets at δ 5.59 and 7.09 ppm with coupling constant 15.8 Hz, confirming the regioselective condensation at the C1 position with (*E*)-stereochemistry at the double bond. The minor C3 regioisomer was also detected in small yield, but could be removed by recrystallization from light petroleum. In the case of alkenoic acid **6b**, only the C1 regioisomer was formed, presumably due to the greater steric influence of the bulkier *tert*-butyl group. Again, the doublets at δ 6.58 and 7.08 ppm (*J* = 16.0 Hz) indicated the formation of the desired *E*-isomer.

Bromination of the alkenoic acids **6** provided the key dibromo acid intermediates **7** in 78-89% yield. This was evidenced by the disappearance of the olefinic doublets and the rise of a new pair of doublets at δ 4.60-4.64 and 4.69-4.72 ppm with a much smaller coupling constant of *J* 1.1-2.6 Hz. The expected *anti*-conformation of acid **7a** was confirmed by spectroscopic data.

Dehydration of the dibromo intermediates **7** with phosphorus pentoxide gave the 3,4-dibromo-dihydrofuran-2-ones **8** as yellow oils. These compounds proved to be difficult to isolate and purify, therefore the crude material was treated directly with 1,8-diazabicyclo[5.4.0]undec-7-ene (DBU) to afford 3-bromofuranones **9** in 63-75% yield. The dehydrobromination reactions proceeded with high regioselectivity and the minor 4-bromofuranone products were not observed. In the proton spectrum of furanone **9a**, the olefinic proton of the methylpropylidene group resonated as a doublet at δ 5.19 ppm while the H4 proton appeared as a singlet at δ 7.39 ppm.

These two protons coupled to each other in the 2D NOESY NMR spectrum confirming the *Z*-stereochemistry of the double bond (Figure 3). For 3-bromofuranone **9b**, the two protons appeared as singlets at  $\delta$  5.26 and 7.35 ppm, respectively.

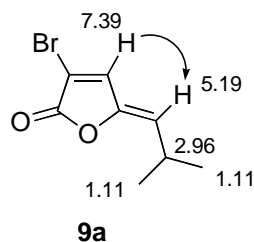

**Figure 3.** NOESY coupling in fimbrolide **9a**.

In contrast, the acid-promoted cyclization of the dibromo intermediates **7** gave the 4-bromofuranone **11** in 25-54% yield in a single reaction. This reaction is postulated to proceed *via* the dehydrobromination intermediate **10**, which then undergoes cyclization and dehydration to yield 4-bromofuranone **11**. This is consistent with observations in related examples.<sup>18</sup> In the <sup>1</sup>H NMR of furanone **11a**, the olefinic proton of the methylpropylidene group resonated as a doublet at  $\delta$  5.44 ppm, while H3 appeared as a singlet  $\delta$  6.32 ppm. For furanone **11b**, these protons appeared as singlets at  $\delta$  5.54 and 6.28 ppm respectively. Although 2D NMR could not establish the stereochemistry of the double bond in 4-bromofuranones, the chemical shift values of these protons were similar to those in the naturally occurring (*Z*)-fimbrolides. Furthermore, the bulky *iso*-propyl and *tert*-butyl groups would be expected to strongly discourage the formation of the *E*-isomer due to steric clashes with the C4 bromine.

This optimized sequence required only one chromatographic purification to furnish the desired 3-bromo or 4-bromofuranones in three to four steps from inexpensive starting materials. This methodology may be readily adapted to the synthesis of a wide range of substituted furanone analogues. Preliminary screening results have demonstrated that some of these synthetic furanones possess AHL-inhibitory activity.

The Suzuki-Miyaura reaction has previously been reported for the synthesis of 3-aryl<sup>16</sup> and 4-aryl-2-(5*H*)-ones<sup>17</sup> lacking the C5 exocyclic double bond, while for fimbrolide analogues the Stille coupling has been tried.<sup>19</sup> Iodinated fimbrolide-like structures have also been subjected to the Suzuki reaction for the synthesis of complex natural products.<sup>20</sup> However, this appears to be the first time that the Suzuki reaction has been applied to close analogues of the natural fimbrolides.

The Suzuki-Miyaura coupling reactions of the 3-bromofuranone **9b** were realized in a biphasic toluene-water (1:1) solvent system with Pd(PPh<sub>3</sub>)Cl<sub>2</sub> as catalyst, CsF as base and Bu<sub>4</sub>Nl as a phase transfer agent. A variety of boronic acids **12a-i** were investigated to give a library of new 3-aryl-5-alkylidenefuran-2-(5*H*)-ones **13a-i** (Table 1).

The identity of the coupling products was confirmed by <sup>1</sup>H and <sup>13</sup>C NMR, HRMS, and elemental analyses. The *Z*-stereochemistry of the exocyclic double bond can be clearly seen from

the crystal structure of 3-(3-fluorophenyl)-5-(2,2-dimethylpropylidene)furan-2(5*H*)-one **13c** (Figure 4).

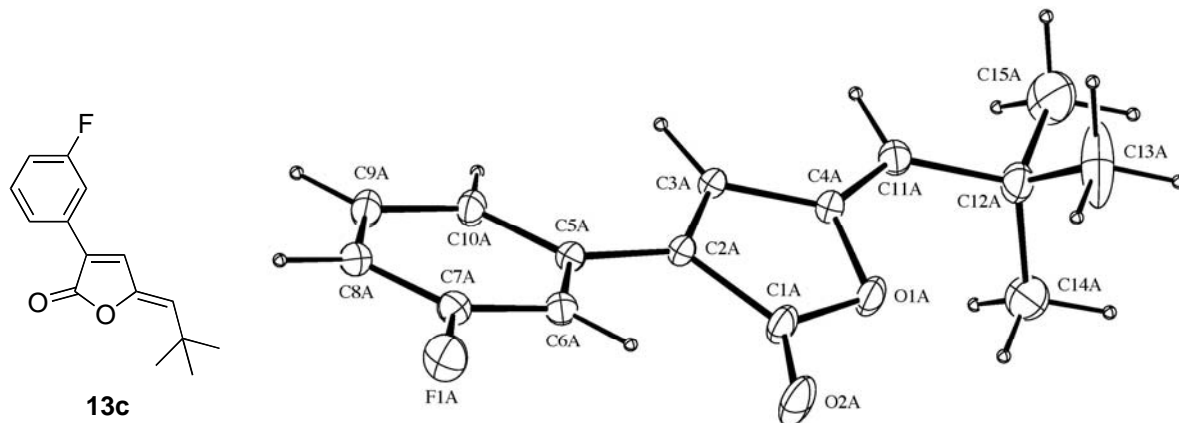

**Figure 4.** X-ray crystal structure of furanone **13c**.

In the  $^1\text{H}$  NMR of the 3-arylfuranones, the exocyclic vinylic proton appeared in the range  $\delta$  5.20-5.40 ppm and H4 at  $\delta$  7.34-7.65 ppm, while in the starting material 3-bromofuranone **9b** these protons resonated  $\delta$  5.26 and 7.35 ppm, respectively. Generally, the substitution of an aryl group for the bromine atom results in a downfield shift for these protons.

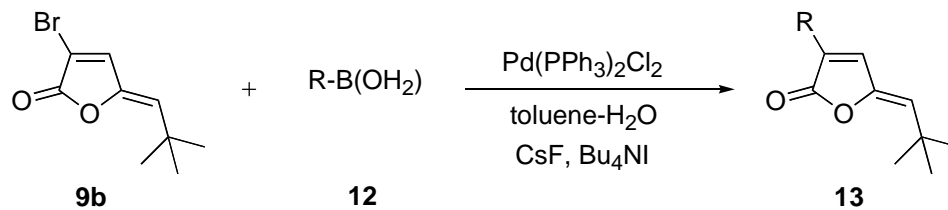
**Table 1.** Suzuki-Miyaura coupling of 3-bromofuranone **9b** with boronic acids **12a-i**<sup>a</sup>

Entry	<b>12</b>	R	Product <b>13</b>	Yield <sup>b</sup> (%)
1	<b>12a</b>		<b>13a</b>	89
2	<b>12b</b>		<b>13b</b>	39
3	<b>12c</b>		<b>13c</b>	66
4	<b>12d</b>		<b>13d</b>	74
5	<b>12e</b>		<b>13e</b>	53
6	<b>12f</b>		<b>13f</b>	61
7	<b>12g</b>		<b>13g</b>	70
8	<b>12h</b>		<b>13h</b>	45
9	<b>12i</b>		<b>13i</b>	21

<sup>a</sup> Reagents and conditions:  $\text{R-B}(\text{OH})_2$  (1.2 equiv),  $\text{CsF}$  (3 equiv),  $\text{Pd}(\text{Ph}_3)\text{Cl}_2$  (0.05 equiv),  $\text{Bu}_4\text{NI}$  (0.05 equiv), reflux, 36 h.

<sup>b</sup> Isolated yields.

Similarly, reaction of 4-bromofuranone **11b** with boronic acids **12b-d** gave 4-aryl-5-alkylidene-furan-2(5*H*)-ones **14a-c** (Scheme 2).

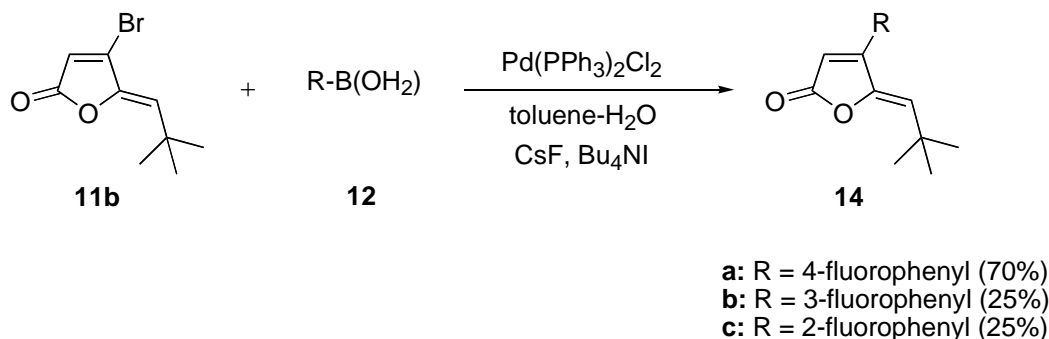

**Scheme 2.** Reagents and conditions: R–B(OH)<sub>2</sub> (1.2 equiv), CsF (3 equiv), Pd(PH<sub>3</sub>)Cl<sub>2</sub> (0.05 equiv), Bu<sub>4</sub>NI (0.05 equiv), reflux, 36 h.

## Conclusions

In summary, we have successfully prepared fimbrolide analogues that have an *iso*-propyl or *tert*-butyl substituent instead of a bromine atom at the exocyclic vinylic position. By employing different cyclization conditions for the key dibromo acid intermediate, both 3- and 4-bromofuranones could be formed. The syntheses require only a few simple steps from simple starting materials and the products are obtained with high stereo- and regioselectivities. The Suzuki-Miyaura reaction was employed to generate 3- and 4-aryl analogues. Overall, the methodologies described represent an efficient access to a range of natural products and their analogues with potentially interesting biological activities.

## Experimental Section

**General Procedures.** Melting points were determined on a Köfler hot stage apparatus and are uncorrected. <sup>1</sup>H NMR spectra were recorded with a Bruker DPX300 (300 MHz) spectrometer and NMR spectral data are reported as follows: chemical shift measured in parts per million (ppm) internally referenced to solvent nuclei (δ); multiplicity; observed coupling constant (*J*) in Hertz (Hz); proton count; assignment. Multiplicities are recorded as singlet (s), doublet (d), triplet (t), quartet (q), multiplet (m) and combinations of these. <sup>13</sup>C NMR spectra were recorded with a Bruker DPX300 spectrometer (75 MHz) and chemical shifts are reported in ppm internally referenced to solvent nuclei (δ), and identifiable carbons are given. Ultraviolet spectra were measured on a Cary 100 spectrophotometer and data are reported as wavelength (λ) in nm and absorption coefficient (ε) in M<sup>-1</sup>cm<sup>-1</sup> in the specified solvent. Infrared spectra were obtained



with a Nicolet Avatar 320 FT-IR spectrometer on KBr discs. Elemental analyses and high resolution mass spectra were performed by the Campbell Microanalytical Laboratory, University of Otago, New Zealand. Flash column chromatography was performed using Merck 60 Silica Gel. X-ray crystal structures were obtained by Don Craig at The University of New South Wales, Sydney, Australia. Crystallography data can be obtained free of charge from The Cambridge Crystallographic Data Centre as number CCDC 692618 (**13c**) via [www.ccdc.cam.ac.uk/data\\_request/cif](http://www.ccdc.cam.ac.uk/data_request/cif). Reagents and solvents were purchased from standard suppliers and were used without further purification.

**(E)-6-Methyl-4-oxohept-2-enoic acid (6a).** To a solution of glyoxylic acid (27.61 g, 0.30 mol) in *ortho*-phosphoric acid (20 mL) was added 4-methyl-2-pentanone **5a** (20.03 g, 0.19 mol). The resulting mixture was stirred at 75 °C for 5 h and left to stand at room temperature overnight. Brine was added and the mixture was extracted with dichloromethane-diethyl ether (1:1, 3 x 50 mL). The combined organic layers were extracted with saturated sodium bicarbonate solution. The aqueous phase was acidified with hydrochloric acid (10 M) and the mixture was extracted with dichloromethane-diethyl ether (1:1, 2 x 50 mL). The combined organic extracts were dried (Na<sub>2</sub>SO<sub>4</sub>) and concentrated under reduced pressure to give a yellow oil (18.5 g, 60%). Recrystallization from hexanes yielded alkenoic acid **6a** as pale yellow crystals (1.8 g, 10%). Mp 77-78 °C (lit.<sup>21</sup> 76-80 °C). <sup>1</sup>H NMR (300 MHz, CDCl<sub>3</sub>) δ 0.94 (m, 6H, CH<sub>3</sub>), 2.19 (m, 1H, CH), 2.53 (d, 2H, *J* = 7.2 Hz, CH<sub>2</sub>), 3.69 (s, 1H, OH), 6.62 (d, 1H, *J* = 15.8 Hz, CH), 7.09 (d, 1H, *J* = 15.8 Hz, CH). <sup>13</sup>C NMR (75.6 MHz, CDCl<sub>3</sub>) δ 22.9 (CH<sub>3</sub>), 25.1 (CH), 50.9 (CH<sub>2</sub>), 129.9 (CH=CHCO<sub>2</sub>H), 141.8 (CH=CHCO<sub>2</sub>H), 170.8 (COOH), 200.5 (CO).

**(E)-6,6-Dimethyl-4-oxohept-2-enoic acid (6b).** This compound was similarly prepared from 4,4-dimethyl-2-pentanone **5b** (2.50 g, 0.02 mol). The crude product was recrystallized from dichloromethane-hexanes to afford alkenoic acid **6b** as white crystals (1.31 g, 40%). Mp 90-92 °C (lit.<sup>22</sup> 91-93 °C). <sup>1</sup>H NMR (300 MHz, CDCl<sub>3</sub>) δ 1.03 (s, 9H, CH<sub>3</sub>), 2.53 (s, 2H, CH<sub>2</sub>), 5.99 (s, 1H, OH), 6.58 (d, 1H, *J* = 16.0 Hz, CH), 7.08 (d, 1H, *J* = 16.0 Hz, CH). <sup>13</sup>C NMR (75.6 MHz, CDCl<sub>3</sub>) δ 29.6 (CH<sub>3</sub>), 31.6 (C(CH<sub>3</sub>)<sub>3</sub>), 54.1 (CH<sub>2</sub>), 129.1 (=CHCOOH), 142.2 (COCH=), 177.1 (COOH), 199.4 (COCH<sub>2</sub>).

**2,3-Dibromo-6-methyl-4-oxoheptanoic acid (7a).** To an ice-cold solution of the alkenoic acid **6a** (0.98 g, 6.34 mmol) in dry dichloromethane (30 mL) was added dropwise a solution of bromine (0.29 mL, 5.63 mmol) in dry dichloromethane (5 mL). The mixture was stirred at -78 °C for 3 h. Saturated aqueous Na<sub>2</sub>S<sub>2</sub>O<sub>5</sub> was added and the organic phase was washed with water (2 x 20 mL), dried (Na<sub>2</sub>SO<sub>4</sub>), and concentrated under reduced pressure. The crude product was recrystallized from hexanes to afford dibromo acid **7a** as white needles (1.56 g, 78%). Mp 82 °C. <sup>1</sup>H NMR (300 MHz, CDCl<sub>3</sub>) δ 1.00 (m, 6H, CH<sub>3</sub>), 2.22 (m, 1H, CH), 2.54 (m, 2H, CH<sub>2</sub>), 4.64 (d, 1H, *J* = 2.6 Hz, CHBr), 4.72 (d, 1H, *J* = 2.6 Hz, CHBr). <sup>13</sup>C NMR (75.6 MHz, CDCl<sub>3</sub>) δ 22.4 (CH<sub>3</sub>), 24.3 (CH), 46.1 (CHBrCO<sub>2</sub>H), 51.7 (COCHBr), 171.0 (CO<sub>2</sub>H), 198.6 (CO). UV (CH<sub>3</sub>OH) λ<sub>max</sub> 206 nm (ε 1997 M<sup>-1</sup>cm<sup>-1</sup>). IR (KBr) ν<sub>max</sub> 3010, 2957, 2925, 2845, 1709, 1467, 1302, 1211, 1039, 907 cm<sup>-1</sup>.

**2,3-Dibromo-6,6-dimethyl-4-oxoheptanoic acid (7b).** This compound was similarly prepared from alkenoic acid **6b** (0.50 g, 2.94 mmol). The crude product was recrystallized from hexanes to yield the dibromo acid **7b** as white needles (0.85 g, 89%). Mp 43-47 °C. <sup>1</sup>H NMR (300 MHz, CDCl<sub>3</sub>) δ 1.03 (m, 9H, CH<sub>3</sub>), 2.63 (m, 2H, CH<sub>2</sub>), 4.60 (d, 1H, *J* = 1.1 Hz, CHBr), 4.69 (d, 1H, *J* = 1.1 Hz, CHBr). <sup>13</sup>C NMR (75.6 MHz, CDCl<sub>3</sub>) δ 29.4 (CH<sub>3</sub>), 31.2 (C(CH<sub>3</sub>)<sub>3</sub>), 45.4 (CHBrCO<sub>2</sub>H), 52.9 (CH<sub>2</sub>), 53.0 (COCHBr), 172.4 (CO<sub>2</sub>H), 202.0 (CO). UV (CH<sub>3</sub>OH) λ<sub>max</sub> 202 nm (ε 11805 M<sup>-1</sup>cm<sup>-1</sup>), 273 (6260). IR (KBr) ν<sub>max</sub> 2960, 1712, 1430, 1317, 1290, 1228, 935, 647 cm<sup>-1</sup>. HRMS (ESI) *m/z* calcd for C<sub>9</sub>H<sub>14</sub>Br<sub>2</sub>O<sub>3</sub>Na (M+Na) 350.9207, found 350.9201.

**3-Bromo-5-(2-methylpropylidene)furan-2(5H)-one (9a).** A mixture of the dibromo acid **7a** (0.37 g, 1.17 mmol) and phosphorous pentoxide (0.50 g, 1.76 mmol) in dry dichloromethane (15 mL) was refluxed for 1 h. The cooled mixture was filtered through a pad of celite-silica-celite. The filtrate was concentrated under reduced pressure to give 3,4-dibromo-dihydro-5-(2-methylpropylidene)furan-2(3H)-one **8** as a yellow oil (0.21 g, 0.70 mmol). To the crude oil was added dropwise a solution of DBU (0.12 g, 0.80 mmol) in dichloromethane (3 mL) and the mixture was stirred at -78 °C for 1 h. The mixture was acidified with hydrochloric acid (2 M) and extracted with dichloromethane (3 x 20 mL). The combined organic layers were dried (Na<sub>2</sub>SO<sub>4</sub>) and the solvent was removed under reduced pressure to give a yellow oil. Purification by column chromatography on silica gel (dichloromethane-hexanes, 1:1) afforded furanone **9a** as a yellow oil (0.16 g, 63%). <sup>1</sup>H NMR (300 MHz, CDCl<sub>3</sub>) δ 1.08 (d, 6H, *J* = 6.8 Hz, CH<sub>3</sub>), 2.96 (m, 1H, CH(CH<sub>3</sub>)<sub>2</sub>), 5.19 (d, 1H, *J* = 9.8 Hz, =CH), 7.39 (s, 1H, H4). <sup>13</sup>C NMR (75.6 MHz, CDCl<sub>3</sub>) δ 22.4 (CH), 26.2 (CH<sub>3</sub>), 111.7 (=CHCH(CH<sub>3</sub>)<sub>2</sub>), 124.8 (C3), 141.5 (C4), 146.2 (C5), 166.7 (C2). UV (CH<sub>3</sub>OH) λ<sub>max</sub> 284 nm (ε 15659 M<sup>-1</sup>cm<sup>-1</sup>). IR (KBr) ν<sub>max</sub> 3083, 2964, 1781, 1466, 1299, 1220, 1095, 991, 904, 754 cm<sup>-1</sup>. MS (MALDI) *m/z* 217 ([M+H]<sup>+</sup> (<sup>79</sup>Br), 100%), 219 ([M+H]<sup>+</sup> (<sup>81</sup>Br), 86%).

**3-Bromo-5-(2,2-dimethylpropylidene)furan-2(5H)-one (9b).** This compound was similarly prepared from dibromo acid **7b** (3.6 g, 10.9 mmol). The desired furanone **9b** was obtained as a yellow solid (1.7 g, 7.4 mmol, 75%). Mp 56-58 °C. <sup>1</sup>H NMR (300 MHz, CDCl<sub>3</sub>) δ 1.24 (m, 9H, CH<sub>3</sub>), 5.26 (s, 1H, =CH), 7.35 (s, 1H, H4). <sup>13</sup>C NMR (75.6 MHz, CDCl<sub>3</sub>) δ 30.7 (CH<sub>3</sub>), 33.6 (C(CH<sub>3</sub>)<sub>3</sub>), 110.6 (=CHC(CH<sub>3</sub>)<sub>3</sub>), 128.0 (C3), 142.9 (C4), 146.1 (C5), 165.6 (C2). UV (CH<sub>3</sub>OH) λ<sub>max</sub> 285 nm (ε 29549 M<sup>-1</sup>cm<sup>-1</sup>). IR (KBr) ν<sub>max</sub> 3309, 2967, 1748, 1560, 1339, 1244, 1220, 1002, 960, 900 cm<sup>-1</sup>. Anal. Calcd for C<sub>9</sub>H<sub>11</sub>BrO<sub>2</sub>: C, 46.78; H, 4.80. Found: C, 46.76; H, 4.78

**4-Bromo-5-(2-methylpropylidene)furan-2(5H)-one (11a).** The dibromo acid **7a** (0.704 g, 2.22 mmol) was dissolved in sulfuric acid (18 M, 5 mL) and the solution was heated at 100 °C for 10 min. The cooled mixture was poured into ice-water (50 mL) and extracted with dichloromethane-diethyl ether (1:1, 3 x 50 mL). The organic phase was washed with saturated sodium bicarbonate solution (30 mL), dried (Na<sub>2</sub>SO<sub>4</sub>), and concentrated under reduced pressure. The crude product was purified by column chromatography on silica gel (dichloromethane-hexanes, 2:3) to yield furanone **11a** as a yellow oil (0.26 g, 54%). <sup>1</sup>H NMR (300 MHz, CDCl<sub>3</sub>) δ 1.10 (m, 6H, CH<sub>3</sub>), 2.97 (m, 1H, CH(CH<sub>3</sub>)<sub>2</sub>), 5.44 (d, 1H, *J* = 9.8 Hz, =CH), 6.32 (s, 1H, H3). <sup>13</sup>C NMR (75.6 MHz, CDCl<sub>3</sub>) δ 22.2 (CH), 26.5 (CH<sub>3</sub>), 119.6 (=CHCH(CH<sub>3</sub>)<sub>2</sub>), 123.7 (C3),

137.1 (C4), 146.5 (C5), 166.9 (C2). UV (CH<sub>3</sub>OH)  $\lambda_{\max}$  245 nm ( $\epsilon$  37150 M<sup>-1</sup>cm<sup>-1</sup>), 335 (27869). IR (KBr)  $\nu_{\max}$  3023, 2969, 1770, 1557, 1215, 1108, 983, 753 cm<sup>-1</sup>. HRMS (ESI)  $m/z$  calcd for C<sub>8</sub>H<sub>9</sub>BrO<sub>2</sub>Na (M+Na)<sup>+</sup> 238.9678, found 238.9672.

**4-Bromo-5-(2,2-dimethylpropylidene)furan-2(5H)-one (11b).** This compound was similarly prepared from 2,3-dibromo-6,6-dimethyl-4-oxoheptanoic acid **7b** (2.0 g, 6.1 mmol). The desired furanone **11b** was obtained as a yellow oil (0.35 g, 1.5 mmol, 25%). <sup>1</sup>H NMR (300 MHz, CDCl<sub>3</sub>)  $\delta$  1.25 (s, 9H, CH<sub>3</sub>), 5.54 (s, 1H, =CH), 6.28 (s, 1H, H3). <sup>13</sup>C NMR (75.6 MHz, CDCl<sub>3</sub>)  $\delta$  29.9 (CH<sub>3</sub>), 33.2 (C(CH<sub>3</sub>)<sub>3</sub>), 118.7 (=CHC(CH<sub>3</sub>)<sub>3</sub>), 126.2 (C3), 138.4 (C4), 146.1 (C5), 167.1 (C2). UV (CH<sub>3</sub>OH)  $\lambda_{\max}$  202 nm ( $\epsilon$  3067 M<sup>-1</sup>cm<sup>-1</sup>), 279 (14830). IR  $\nu_{\max}$  3140, 2963, 2870, 1770, 1560, 1267, 1224, 1109, 985, 941, 908, 804 cm<sup>-1</sup>. HRMS (ESI)  $m/z$  calcd for C<sub>9</sub>H<sub>11</sub>BrO<sub>2</sub>Na (M+Na)<sup>+</sup> 252.9840, found 252.9847.

### General procedure for Suzuki-Miyaura coupling reactions

To a solution of the furanone **9** or **11** (231 mg, 1.00 mmol) in toluene (10 mL) and water (10 mL) was added boronic acid **12** (1.20 mmol), CsF (456 mg, 3.00 mmol), Bu<sub>4</sub>Ni (18 mg, 0.05 mmol) and Pd(PPh<sub>3</sub>)Cl<sub>2</sub> (35 mg, 0.05 mmol). The mixture was refluxed for 36 hours under a nitrogen atmosphere. Brine (40 mL) was added and the mixture was extracted with ethyl acetate (3 x 50 mL). The combined organic layers were dried (Na<sub>2</sub>SO<sub>4</sub>) and the solvent was removed under reduced pressure. The crude product was purified by flash chromatography on silica gel and recrystallized from dichloromethane-hexanes.

**5-(2,2-Dimethylpropylidene)-3-phenylfuran-2(5H)-one (13a).** Yellow crystals (89%). Mp 59-62 °C. <sup>1</sup>H NMR (300 MHz, CDCl<sub>3</sub>)  $\delta$  1.29 (s, 9H, CH<sub>3</sub>), 5.27 (s, 1H, =CH), 7.38-7.42 (m, 4H, ArH), 7.39 (s, 1H, H4), 7.85-7.86 (m, 1H, ArH). <sup>13</sup>C NMR (75.6 MHz, CDCl<sub>3</sub>)  $\delta$  30.3 (CH<sub>3</sub>), 33.3 (C(CH<sub>3</sub>)<sub>3</sub>), 126.6 (=CHC(CH<sub>3</sub>)<sub>3</sub>), 126.9 (Ar), 128.4 (Ar), 128.6 (Ar), 129.2 (Ar), 129.5 (C3), 136.8 (C4), 146.2 (C5), 168.8 (C2). UV (CH<sub>3</sub>OH)  $\lambda_{\max}$  203 nm ( $\epsilon$  28185 M<sup>-1</sup>cm<sup>-1</sup>), 232 (20212), 312 (49152). IR (KBr)  $\nu_{\max}$  3100, 2957, 1750, 1447, 1295, 1096, 962, 906, 787, 746 cm<sup>-1</sup>. HRMS (ESI)  $m/z$  calcd for C<sub>15</sub>H<sub>17</sub>O<sub>2</sub> (M+H)<sup>+</sup> 229.1229, found 229.1236. Anal. Calcd for C<sub>15</sub>H<sub>16</sub>O<sub>2</sub>: C, 78.92; H, 7.06. Found: C, 78.62; H, 7.22.

**3-(4-Fluorophenyl)-5-(2,2-dimethylpropylidene)furan-2(5H)-one (13b).** White needles (39%). Mp 129-131 °C. <sup>1</sup>H NMR (300 MHz, CDCl<sub>3</sub>)  $\delta$  1.28 (s, 9H, CH<sub>3</sub>), 5.27 (s, 1H, =CH), 7.10 (m, 2H, ArH), 7.34 (s, 1H, 4H), 7.85-7.90 (m, 2H, ArH). <sup>13</sup>C NMR (75.6 MHz, CDCl<sub>3</sub>)  $\delta$  30.2 (CH<sub>3</sub>), 33.3 (C(CH<sub>3</sub>)<sub>3</sub>), 115.6 (Ar), 115.9 (=CHC(CH<sub>3</sub>)<sub>3</sub>), 128.8 (Ar), 128.9 (C3), 136.4 (C4), 146.0 (C5), 161.5 (Ar), 164.8 (Ar), 168.7 (C2). UV (CH<sub>3</sub>OH)  $\lambda_{\max}$  203 nm ( $\epsilon$  23234 M<sup>-1</sup>cm<sup>-1</sup>), 232 (16662), 310 (47453). IR (KBr)  $\nu_{\max}$  3085, 2961, 1754, 1507, 1344, 1295, 1235, 1165, 1108, 965, 835, 528 cm<sup>-1</sup>. HRMS (ESI)  $m/z$  calcd for C<sub>15</sub>H<sub>16</sub>FO<sub>2</sub> (M+H)<sup>+</sup> 247.1134, found 247.1120.

**3-(3-Fluorophenyl)-5-(2,2-dimethylpropylidene)furan-2(5H)-one (13c).** White needles (66%). Mp 62-65 °C. <sup>1</sup>H NMR (300 MHz, CDCl<sub>3</sub>)  $\delta$  1.28 (s, 9H, CH<sub>3</sub>), 5.31 (s, 1H, =CH), 7.05-7.06 (m, 1H, ArH), 7.36-7.39 (m, 1H, ArH), 7.41 (s, 1H, H4), 7.60-7.61 (m, 2H, ArH). <sup>13</sup>C NMR (75.6 MHz, CDCl<sub>3</sub>)  $\delta$  30.2 (CH<sub>3</sub>), 33.4 (C(CH<sub>3</sub>)<sub>3</sub>), 114.0 (Ar), 115.9 (=CHC(CH<sub>3</sub>)<sub>3</sub>), 122.6 (Ar), 127.7 (Ar), 130.1 (Ar), 131.4 (C3), 137.6 (C4), 146.0 (C5), 161.2 (Ar), 164.4 (Ar), 168.3 (C2). UV

(CH<sub>3</sub>OH)  $\lambda_{\max}$  204 nm ( $\epsilon$  40655 M<sup>-1</sup>cm<sup>-1</sup>), 230 (21748), 309 (66060). IR (KBr)  $\nu_{\max}$  3118, 2963, 1748, 1652, 1489, 1345, 1280, 1224, 1090, 966, 904, 763 cm<sup>-1</sup>. HRMS (ESI)  $m/z$  calcd for C<sub>15</sub>H<sub>16</sub>FO<sub>2</sub> (M+H)<sup>+</sup> 247.1134, found 247.1123. Anal. Calcd for C<sub>15</sub>H<sub>15</sub>FO<sub>2</sub>: C, 73.15; H, 6.14. Found: C, 73.08; H, 6.24.

**3-(2-Fluorophenyl)-5-(2,2-dimethylpropylidene)furan-2(5H)-one (13d).** White needles (74%). Mp 91-94 °C. <sup>1</sup>H NMR (300 MHz, CDCl<sub>3</sub>)  $\delta$  1.29 (s, 9H, CH<sub>3</sub>), 5.34 (s, 1H, =CH), 7.09-7.64 (m, 3H, ArH), 7.65 (s, 1H, H4), 8.28-8.29 (m, 1H, ArH). <sup>13</sup>C NMR (75.6 MHz, CDCl<sub>3</sub>)  $\delta$  30.2 (CH<sub>3</sub>), 33.4 (C(CH<sub>3</sub>)<sub>3</sub>), 115.8 (=CHC(CH<sub>3</sub>)<sub>3</sub>), 117.9 (Ar), 124.3 (Ar), 127.8 (Ar), 129.5 (Ar), 130.4 (C3), 140.1 (C4), 146.3 (C5), 161.2 (Ar), 164.4 (Ar), 168.9 (C2). UV (CH<sub>3</sub>OH)  $\lambda_{\max}$  202 nm ( $\epsilon$  23208 M<sup>-1</sup>cm<sup>-1</sup>), 230 (7258), 310 (23759). IR (KBr)  $\nu_{\max}$  3097, 2960, 1752, 1440, 1330, 1193, 1097, 967, 864, 788 cm<sup>-1</sup>. HRMS (ESI)  $m/z$  calcd for C<sub>15</sub>H<sub>16</sub>FO<sub>2</sub> (M+H)<sup>+</sup> 247.1134, found 247.1107. Anal. Calcd for C<sub>15</sub>H<sub>15</sub>FO<sub>2</sub>: C, 73.15; H, 6.14. Found: C, 73.03; H, 6.18.

**3-(2,4-Difluorophenyl)-5-(2,2-dimethylpropylidene)furan-2(5H)-one (13e).** Yellow crystals (53%). Mp 156-157 °C. <sup>1</sup>H NMR (300 MHz, CDCl<sub>3</sub>)  $\delta$  1.28 (s, 9H, CH<sub>3</sub>), 5.34 (s, 1H, =CH), 6.86-7.00 (m, 2H, ArH), 7.60 (s, 1H, H4), 8.30-8.31 (m, 1H, ArH). <sup>13</sup>C NMR (75.6 MHz, CDCl<sub>3</sub>)  $\delta$  30.2 (CH<sub>3</sub>), 33.4 (C(CH<sub>3</sub>)<sub>3</sub>), 104.3 (Ar), 114.3 (Ar), 111.7 (=CHC(CH<sub>3</sub>)<sub>3</sub>), 128.0 (Ar), 130.6 (Ar), 121.0 (C3), 140.4 (C4), 146.2 (C5), 162.8 (Ar), 164.4 (Ar), 168.8 (C2). UV (CH<sub>3</sub>OH)  $\lambda_{\max}$  202 nm ( $\epsilon$  16678 M<sup>-1</sup>cm<sup>-1</sup>), 228 (8442), 306 (30655). IR (KBr)  $\nu_{\max}$  3130, 2960, 1751, 1586, 1501, 1422, 1282, 1141, 1090, 913, 840, 813, 772, 712, 590 cm<sup>-1</sup>. HRMS (ESI)  $m/z$  calcd for C<sub>15</sub>H<sub>15</sub>F<sub>2</sub>O<sub>2</sub> (M+H)<sup>+</sup> 265.1040, found 265.1021. Anal. Calcd for C<sub>15</sub>H<sub>14</sub>F<sub>2</sub>O<sub>2</sub>: C, 68.17; H, 5.34. Found: C, 68.10; H, 5.36.

**3-(4-(Trifluoromethyl)phenyl)-5-(2,2-dimethylpropylidene)furan-2(5H)-one (13f).** Yellow crystals (61%). Mp 120-122 °C. <sup>1</sup>H NMR (300 MHz, CDCl<sub>3</sub>)  $\delta$  1.29 (s, 9H, CH<sub>3</sub>), 5.36 (s, 1H, =CH), 7.50 (s, 1H, H4), 7.65-7.68 (d,  $J$  = 8.1 Hz, 2H, ArH), 7.97-7.98 (d,  $J$  = 8.1 Hz, 2H, ArH). <sup>13</sup>C NMR (75.6 MHz, CDCl<sub>3</sub>)  $\delta$  30.2 (CH<sub>3</sub>), 33.5 (C(CH<sub>3</sub>)<sub>3</sub>), 122.0 (Ar), 125.6 (=CHC(CH<sub>3</sub>)<sub>3</sub>), 125.6 (Ar), 127.1 (Ar), 129.5 (CF<sub>3</sub>), 130.6 (C3), 132.9 (Ar), 138.5 (C4), 146.0 (C5), 168.3 (C2). UV (CH<sub>3</sub>OH)  $\lambda_{\max}$  202 nm ( $\epsilon$  29392 M<sup>-1</sup>cm<sup>-1</sup>), 229 (13986), 308 (53744). IR (KBr)  $\nu_{\max}$  3078, 2962, 1754, 1332, 1160, 1129, 1071, 967, 720 cm<sup>-1</sup>. HRMS (ESI)  $m/z$  calcd for C<sub>16</sub>H<sub>16</sub>F<sub>3</sub>O<sub>2</sub> (M+H)<sup>+</sup> 297.1102, found 297.1060. Anal. Calcd for C<sub>16</sub>H<sub>15</sub>F<sub>3</sub>O<sub>2</sub>: C, 64.86; H, 5.10. Found: C, 65.00; H, 5.14.

**3-(3-(Trifluoromethyl)phenyl)-5-(2,2-dimethylpropylidene)furan-2(5H)-one (13g).** Yellow crystals (70%). Mp 118-122 °C. <sup>1</sup>H NMR (300 MHz, CDCl<sub>3</sub>)  $\delta$  1.29 (s, 9H, CH<sub>3</sub>), 5.35 (s, 1H, =CH), 7.49 (s, 1H, H4), 7.52-7.64 (m, 2H, ArH), 8.09-8.13 (m, 2H, ArH). <sup>13</sup>C NMR (75.6 MHz, CDCl<sub>3</sub>)  $\delta$  30.2 (CH<sub>3</sub>), 33.5 (C(CH<sub>3</sub>)<sub>3</sub>), 122.0 (Ar), 123.6 (Ar), 123.7 (Ar), 125.7 (=CHC(CH<sub>3</sub>)<sub>3</sub>), 125.7 (Ar), 126.9 (Ar), 128.2 (Ar), 130.2 (CF<sub>3</sub>), 130.9 (C3), 138.0 (C4), 145.9 (C5), 168.3 (C2). UV (CH<sub>3</sub>OH)  $\lambda_{\max}$  202 nm ( $\epsilon$  20999 M<sup>-1</sup>cm<sup>-1</sup>), 231 (13184), 309 (42387). IR (KBr)  $\nu_{\max}$  2965, 1772, 1655, 1431, 1350, 1281, 1164, 1121, 1097, 882, 808, 695, 677 cm<sup>-1</sup>. HRMS (ESI)  $m/z$  calcd for C<sub>16</sub>H<sub>16</sub>F<sub>3</sub>O<sub>2</sub> (M+H)<sup>+</sup> 297.1102, found 297.1073. Anal. Calcd for C<sub>16</sub>H<sub>15</sub>F<sub>3</sub>O<sub>2</sub>: C, 64.86; H, 5.10. Found: C, 65.15; H, 5.18.

**3-(4-Cyanophenyl)-5-(2,2-dimethylpropylidene)furan-2(5H)-one (13h).** Yellow crystals (45%). Mp 150-153 °C. <sup>1</sup>H NMR (300 MHz, CDCl<sub>3</sub>) δ 1.29 (s, 9H, CH<sub>3</sub>), 5.40 (s, 1H, =CH), 7.52 (s, 1H, 4H), 7.71-7.86 (d, *J* = 8.7 Hz, 2H, ArH), 7.99-8.01 (d, *J* = 8.7 Hz, 2H, ArH). <sup>13</sup>C NMR (75.6 MHz, CDCl<sub>3</sub>) δ 30.1 (CH<sub>3</sub>), 33.6 (C(CH<sub>3</sub>)<sub>3</sub>), 112.5 (Ar), 118.4 (CN), 126.4 (Ar), 127.6 (=CHC(CH<sub>3</sub>)<sub>3</sub>), 129.4 (Ar), 132.4 (Ar), 133.8 (C3), 139.1 (C4), 145.9 (C5), 168.0 (C2). UV (CH<sub>3</sub>OH) λ<sub>max</sub> 203 nm (ε 22227 M<sup>-1</sup>cm<sup>-1</sup>), 317 (51758). IR (KBr) ν<sub>max</sub> 3084, 2970, 2221, 1784, 1766, 1606, 1296, 1090, 956, 902, 846, 553 cm<sup>-1</sup>. HRMS (ESI) *m/z* calcd for C<sub>16</sub>H<sub>15</sub>NO<sub>2</sub>Na (M+Na) 276.1000, found 276.0996. Anal. Calcd for C<sub>16</sub>H<sub>15</sub>NO<sub>2</sub>: C, 75.85; H, 5.97; N, 5.53. Found: C, 75.53; H, 6.28; N, 5.27.

**3-(1H-Indol-5-yl)-5-(2,2-dimethylpropylidene)furan-2(5H)-one (13i).** Yellow crystals (21%). Mp 168-171 °C. <sup>1</sup>H NMR (300 MHz, CDCl<sub>3</sub>) δ 1.29 (s, 9H, CH<sub>3</sub>), 5.20 (s, 1H, =CH), 6.60-6.61 (m, 1H, ArH), 7.22-7.23 (m, 1H, ArH), 7.34 (s, 1H, 4H), 7.41 (d, 1H, *J* = 8.6 Hz, ArH), 7.64 (d, 1H, *J* = 8.6 Hz, ArH), 8.31 (s, 1H, ArH). <sup>13</sup>C NMR (75.6 MHz, CDCl<sub>3</sub>) δ 30.4 (CH<sub>3</sub>), 33.2 (C(CH<sub>3</sub>)<sub>3</sub>), 103.5 (Ar), 110.3 (Ar), 111.3 (=CHC(CH<sub>3</sub>)<sub>3</sub>), 121.0 (Ar), 121.5 (Ar), 124.0 (Ar), 125.0 (Ar), 127.5 (Ar), 128.0 (Ar), 134.7 (C4), 136.1 (C3), 146.3 (C5), 168.9 (C2). UV (CH<sub>3</sub>OH) λ<sub>max</sub> 202 nm (ε 23208 M<sup>-1</sup>cm<sup>-1</sup>), 230 (7258), 310 (23759). IR (KBr) ν<sub>max</sub> 3097, 2960, 1752, 1440, 1330, 1193, 1097, 967, 864, 788 cm<sup>-1</sup>. HRMS (ESI) *m/z* calcd for C<sub>17</sub>H<sub>18</sub>NO<sub>2</sub> (M+H)<sup>+</sup> 268.1338, found 268.1312.

**4-(4-Fluorophenyl)-5-(2,2-dimethylpropylidene)furan-2(5H)-one (14a).** White solid (70%). Mp 59-62 °C. <sup>1</sup>H NMR (300 MHz, CDCl<sub>3</sub>) δ 1.27 (s, 9H, CH<sub>3</sub>), 5.32 (s, 1H, =CH), 6.08 (s, 1H, 3H), 7.14-7.20 (m, 2H, ArH), 7.38-7.40 (m, 2H, ArH). <sup>13</sup>C NMR (75.6 MHz, CDCl<sub>3</sub>) δ 30.3 (CH<sub>3</sub>), 33.3 (C(CH<sub>3</sub>)<sub>3</sub>), 114.4 (=CHC(CH<sub>3</sub>)<sub>3</sub>), 115.9 (Ar), 126.6 (Ar), 130.3 (C3), 147.2 (C5), 157.2 (C4), 162.1(Ar), 165.5(Ar), 168.5 (C2). UV (CH<sub>3</sub>OH) λ<sub>max</sub> 201 nm (ε 7937 M<sup>-1</sup>cm<sup>-1</sup>), 294 (5866). IR (KBr) ν<sub>max</sub> 2963, 2869, 1770, 1613, 1505, 1327, 1231, 1161, 1083, 977, 833, 799, 584 cm<sup>-1</sup>. HRMS (ESI) *m/z* calcd for C<sub>15</sub>H<sub>15</sub>FO<sub>2</sub>Na (M+Na)<sup>+</sup> 269.0954, found 269.0955.

**4-(3-Fluorophenyl)-5-(2,2-dimethylpropylidene)furan-2(5H)-one (14b).** Yellow solid (25%). Mp 42-44 °C. <sup>1</sup>H NMR (300 MHz, CDCl<sub>3</sub>) δ 1.27 (s, 9H, CH<sub>3</sub>), 5.35 (s, 1H, =CH), 6.11 (s, 1H, 3H), 7.10-7.13 (m, 1H, ArH), 7.17-7.22 (m, 2H, ArH), 7.44-7.47 (m, 1H, ArH). <sup>13</sup>C NMR (75.6 MHz, CDCl<sub>3</sub>) δ 30.2 (CH<sub>3</sub>), 33.3 (C(CH<sub>3</sub>)<sub>3</sub>), 115.0 (=CHC(CH<sub>3</sub>)<sub>3</sub>), 115.7 (Ar), 117.2 (Ar), 124.2 (Ar), 126.7 (Ar), 130.5 (C3), 147.0 (C5), 156.9 (C4), 160.9(Ar), 164.1(Ar), 168.4 (C2). UV (CH<sub>3</sub>OH) λ<sub>max</sub> 202 nm (ε 19408 M<sup>-1</sup>cm<sup>-1</sup>), 239 (9926), 334 (19162). IR (KBr) ν<sub>max</sub> 3100, 1771, 1576, 1432, 1272, 1197, 1182, 930, 874, 796, 682 cm<sup>-1</sup>. HRMS (ESI) *m/z* calcd for C<sub>15</sub>H<sub>15</sub>FO<sub>2</sub>Na (M+Na)<sup>+</sup> 269.0954, found 269.0948.

**4-(2-Fluorophenyl)-5-(2,2-dimethylpropylidene)furan-2(5H)-one (14c).** Yellow solid (25%). Mp 39-41 °C. <sup>1</sup>H NMR (300 MHz, CDCl<sub>3</sub>) δ 1.26 (s, 9H, CH<sub>3</sub>), 5.23 (s, 1H, =CH), 6.19 (s, 1H, 3H), 7.17-7.23 (m, 1H, ArH), 7.31-7.34 (m, 2H, ArH), 7.43-7.50 (m, 1H, ArH). <sup>13</sup>C NMR (75.6 MHz, CDCl<sub>3</sub>) δ 30.2 (CH<sub>3</sub>), 33.4 (C(CH<sub>3</sub>)<sub>3</sub>), 116.2(=CHC(CH<sub>3</sub>)<sub>3</sub>), 124.3 (Ar), 126.3 (Ar), 130.5 (C3), 131.7 (Ar), 146.9 (C5), 151.8 (C4), 161.0(Ar), 165.1 (Ar), 168.7 (C2). UV (CH<sub>3</sub>OH) λ<sub>max</sub> 202 nm (ε 13885 M<sup>-1</sup>cm<sup>-1</sup>), 281 (16941). IR (KBr) ν<sub>max</sub> 2961, 1764, 1490, 1261, 1234, 1082, 977, 830, 770 cm<sup>-1</sup>. HRMS (ESI) *m/z* calcd for C<sub>15</sub>H<sub>15</sub>FO<sub>2</sub>Na (M+Na)<sup>+</sup> 269.0954, found 269.0975.

## Acknowledgements

Financial support from the Australian Research Council is gratefully acknowledged.

## References and Notes

1. Alanis, A. J. *Arch. Med. Res.* **2005**, *36*, 697.
2. Livermore, D. M. *Clin. Infect. Dis.* **2003**, *36*, S11.
3. Fuqua, W. C.; Winans, S. C.; Greenberg, E. P. *J. Bacteriol.* **1994**, *176*, 269.
4. Rice, S. A.; McDougald, D.; Kumar, N.; Kjelleberg, S. *Curr. Opin. Investig. D.* **2005**, *6*, 178.
5. Parsek, M. R.; Val, D. L.; Hanzelka, B. L.; Cronan, J. E., Jr.; Greenberg, E. P. *Proc. Natl. Acad. Sci. USA* **1999**, *96*, 4360.
6. Givskov, M.; de Nys, R.; Manefield, M.; Gram, L.; Maximilien, R.; Eberl, L.; Molin, S.; Steinberg, P. D.; Kjelleberg, S. *J. Bacteriol.* **1996**, *178*, 6618.
7. Manefield, M.; de Nys, R.; Kumar, N.; Read, R.; Givskov, M.; Steinberg, P.; Kjelleberg, S. *Microbiology* **1999**, *145*, 283.
8. Hentzer, M.; Riedel, K.; Rasmussen, T. B.; Heydorn, A.; Andersen, J. B.; Parsek, M. R.; Rice, S. A.; Eberl, L.; Molin, S.; Hoiby, N.; Kjelleberg, S.; Givskov, M. *Microbiology* **2002**, *148*, 87.
9. Hentzer, M.; Wu, H.; Andersen, J. N.; Riedel, K.; Rasmussen, T. B.; Bagge, N.; Kumar, N.; Schembri, M. A.; Song, Z.; Kristoffersen, P.; Manefield, M.; Costerton, J. W.; Molin, S.; Eberl, L.; Steinberg, P.; Kjelleberg, S.; Hoiby, N.; Givskov, M. *EMBO* **2003**, *22*, 3803.
10. Wu, H.; Song, Z.; Hentzer, M.; Andersen, J. B.; Molin, S.; Givskov, M.; Hoiby, N. *J. Antimicrob. Chemoth.* **2004**, *53*, 1054.
11. de Nys, R.; Givskov, M.; Kumar, N.; Kjelleberg, S.; Steinberg, P. D. In *Antifouling compounds*; Fusetani, N., Clare, A. S., Ed.; Springer-Verlag: Berlin, Heidelberg, 2006; Vol. 42, pp 55-85.
12. Alvi, K. A.; Casey, A.; Nair, B. G. *J. Antibiot.* **1997**, *51*, 515.
13. Bouzard, D.; Di Cesare, P.; Essiz, M.; Jacquet, J. P.; Remuzon, P.; Weber, A.; Oki, T.; Masuyoshi, M. *J. Med. Chem.* **1989**, *32*, 537.
14. Klopman, G.; Fercu, D.; Renau, T. E.; Jacobs, M. R. *Antimicrob. Agents Ch.* **1996**, *40*, 2637.
15. Miyaura, N.; Suzuki, A. *Chemical Reviews* **1995**, *95*, 2457.
16. Song, Y. S.; Lee, Y.-J.; Kim, B. T.; Heo, J.-N. *Tetrahedron Lett.* **2006**, *47*, 7427.
17. Boukouvalas, J.; Lachance, N.; Ouellet, M.; Trudeau, M. *Tetrahedron Lett.* **1998**, *39*, 7665.
18. Kumar, N.; Read, R., PCT Int. Appl. AU02/00781, 2002.
19. Sorg, A.; Siegel, K.; Brückner, R. *Synlett* **2004**, 0321.
20. Willis, C.; Bodio, E.; Bourdreux, Y.; Billaud, C.; Gall, T. L.; Mioskowski, C. *Tetrahedron Lett.* **2007**, *48*, 6421.
21. Jakubec, P.; Berkeš, D.; Kolarovič, A.; Považanec, F. *Synthesis* **2006**, *23*, 4032.
22. Kawashima, M.; Sato, T.; Fujisawa, T. *B. Chem. Soc. Jpn.* **1988**, *61*, 3255.