

# Synthesis and antiviral activity of novel [1,2,4]triazolo[3,4-*b*][1,3,4]thiadiazoles, [1,2,4]triazolo[3,4-*b*] [1,3,4]thiadiazines and [1,2,4]triazolo[3,4-*b*][1,3,4] thiadiazepines

Abdel-Rahman Farghaly<sup>a</sup>, Erik De Clercq,<sup>b</sup> and Hussein El-Kashef<sup>a\*</sup>

<sup>a</sup>Chemistry Department, Faculty of Science, Assiut University, 71516 Assiut, Egypt

<sup>b</sup>Rega Institute for Medical Research, Katholieke Universiteit Leuven, B-3000 Leuven, Belgium

E-mail: [elkashef15@hotmail.com](mailto:elkashef15@hotmail.com)

---

## Abstract

Starting from the 4-amino-3-(1,3-diphenyl-1*H*-pyrazol-4-yl)-4,5-dihydro-[1,2,4] triazole-5(1*H*)-thione **2**, a series of new [1,3,4]thiadiazoles **3**, **4**, **7** and [1,3,4] thiadiazines **8**, **10**, **11**, **12**, **14** were prepared. Also, [1,3,4]thiadiazepines **16-18** could be synthesized. Some of the newly prepared compounds were evaluated for their antiviral potential.

**Keywords:** 1,3,4-Thiadiazoles, 1,3,4-thiadiazines, 1,3,4-thiadiazepines and antiviral activity

---

## Introduction

Recently, it was reported that the [1,2,4]triazolo[3,4-*b*][1,3,4]thiadiazoles and [1,2,4]triazolo[3,4-*b*][1,3,4]thiadiazines possess antimicrobial activities.<sup>1</sup> Also, 6-substituted 3-(1-adamantyl)-1,2,4-triazolo[3,4-*b*][1,3,4]thiadiazoles have been evaluated for their antiviral activity.<sup>2</sup> The [1,2,4]triazoles and [1,3,4]thiadiazoles are known for their broad-spectrum of biological activities and many other uses.<sup>3-7</sup> Moreover, the triazolothiadiazoles substituted in the 3 and 6 positions by aryl, alkyl or heterocyclic moiety possess pharmacological activity such as antibacterial,<sup>8</sup> anti-inflammatory,<sup>9</sup> herbicidal<sup>10</sup> and anti-HIV-1 effects.<sup>11</sup> On the other hand, it has been reported that certain compounds bearing a thiadiazole and 1,2,4-triazole nucleus possess significant anti-inflammatory activity.<sup>5,12-15</sup> In addition, it was mentioned that [1,3,4]thiadiazoles exhibit various biological activities possibly due to the presence of the =N-C-S moiety.<sup>16</sup> The synthesis of triazoles fused to another heterocyclic ring has attracted particular attention due to their diverse applications as antibacterial, antidepressant, antiviral, antitumoral and anti-inflammatory agents, pesticides, herbicides, lubricant and analytical reagents.<sup>16,17</sup> A number of triazoles fused to thiadiazines or thiadiazoles are incorporated into a wide variety of therapeutically important compounds possessing a broad spectrum of biological activities.<sup>17-20</sup> In

---

\* Corresponding author: Tel: +20 105075881; Fax: +2088 2354130

view of these findings and in continuation to our previous work<sup>21</sup> on the synthesis of [1,3,4]oxadiazoles, [1,2,4]triazoles and [1,3,4]thiadiazines we report herein the synthesis of novel [1,2,4]triazolo[3,4-*b*][1,3,4]thiadiazoles, [1,2,4]triazolo[3,4-*b*][1,3,4]thiadiazines and [1,2,4]triazolo[3,4-*b*][1,3,4]thiadiazepines.

## Results and Discussion

The starting material 4-amino-3-(1,3-diphenyl-1*H*-pyrazol-4-yl)-4,5-dihydro-[1,2,4]triazole-5(1*H*)-thione **2** was prepared in good yield: by the reaction of the oxadiazole thione **1** with hydrazine hydrate. The latter compound is useful intermediate for the synthesis of triazolothiadiazoles, triazolothiadiazines and triazolothiadiazepines. The amino and mercapto groups are ready-made nucleophilic centers for the synthesis of condensed heterocyclic rings.<sup>1</sup> Thus, an attempt to prepare the oxo-analog of **4** by treatment of **2** with ethyl chloroformate in dry benzene was unsuccessful and the product obtained was identified as the S-substituted derivative **5** which could not be cyclized into **3** on boiling in pyridine. However, compound **3** could be obtained via the interaction of amino thione **2** with 1,1'-carbonyldiimidazole (CDI) in dry dioxane. Treatment of **3** with P<sub>2</sub>S<sub>5</sub> in dry pyridine resulted in the formation of the thione derivative **4**. This latter compound could be obtained directly by the reaction of **2** with carbon disulphide in ethanolic KOH (Scheme 1).

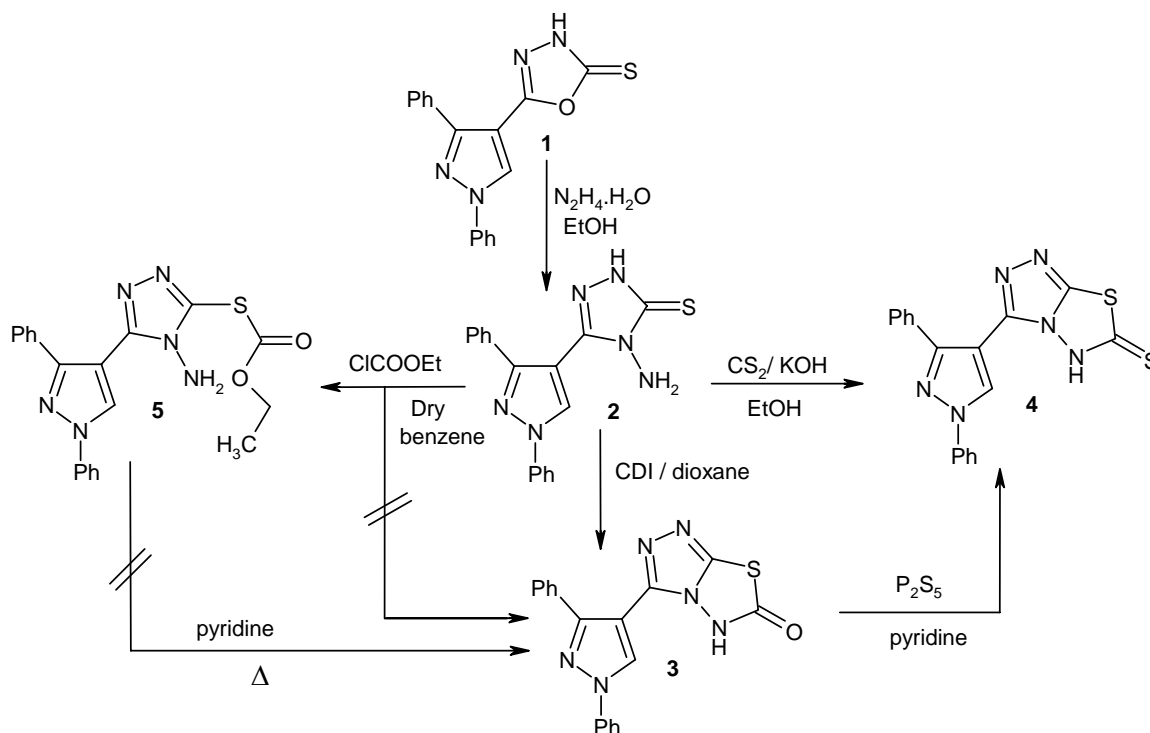

**Scheme 1.** Synthetic pathways for the preparation of compounds **3-5**.

Treatment of triazolethione **2** with acetyl- or benzoyl chloride in refluxing dioxane did not afford the bicyclic structure triazolothiadiazoles **7a,b** but gave the acetyl- or benzoyl amino derivatives **6a,b** respectively. Compounds **6a,b** could be smoothly cyclidehydrated by boiling in phosphoryl chloride affording the [1,2,4]triazolo[3,4-*b*] [1,3,4]thiadiazoles **7a,b** in good yield. It is worthy to note that compound **7a** could be obtained, in a rather better yield: (82 %), directly by the reaction of **2** with acetic acid in boiling phosphoryl chloride. The IR spectrum of the latter compound showed no NH bands and the  $^1\text{H}$  NMR spectrum showed a singlet at 2.71 ppm corresponding to the methyl substituent at position 6 (Scheme 2). From the above reactions we could conclude that the cyclidehydration could only occur in the presence of phosphoryl chloride; the acid chlorides under the used reaction conditions could only give the corresponding acyl(benzoyl)amino derivatives.

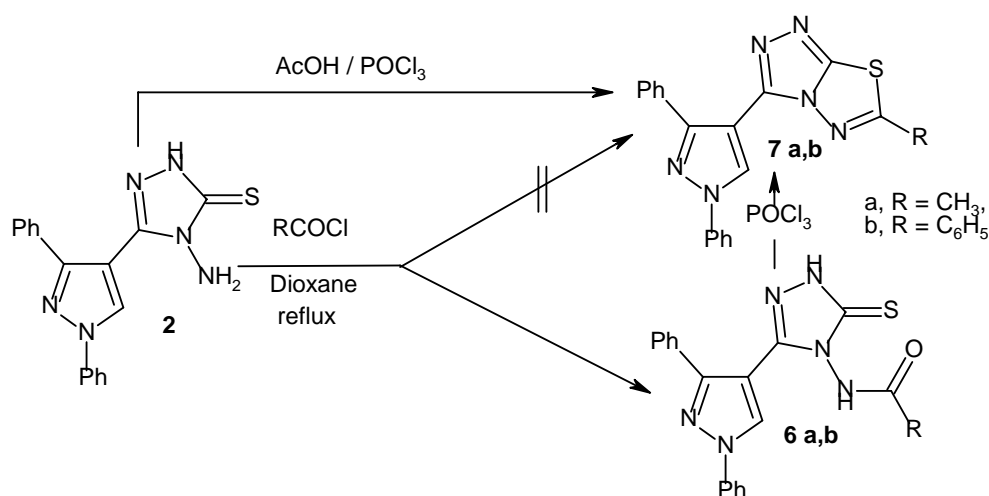

**Scheme 2.** Synthetic pathways for the preparation of compounds **6, 7**.

On the other hand, interaction of the triazolethione **2** with chloro acetonitrile and sodium acetate fused in refluxing ethanol led to the formation of the corresponding 6-amino-3-(1,3-diphenyl-1*H*-pyrazol-4-yl)-7*H*-[1,2,4]triazolo[3,4-*b*][1,3,4]thiadiazine (**8**) in 90 % yield. Interaction of **2** with chloroacetone and  $\alpha$ -bromoacetophenone in boiling ethanol afforded the corresponding triazolo[3,4-*b*][1,3,4]thiadiazines **9a,b** (Scheme 3).

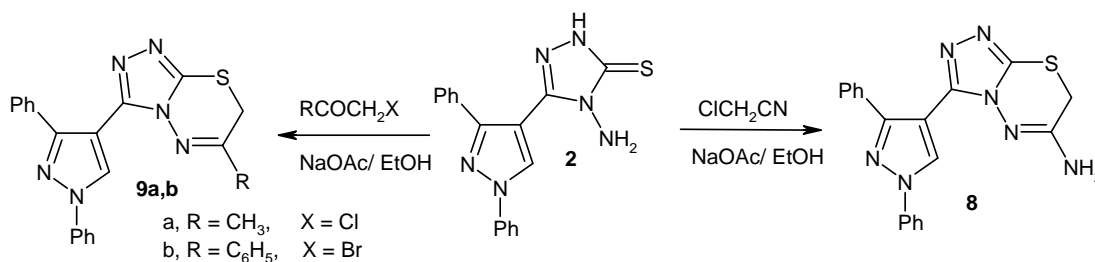

**Scheme 3.** Synthetic pathways for the preparation of triazolothiadiazines **8, 9**.

Treatment of the amino thione **2** with ethyl chloroacetate gave a product whose NMR spectrum showed a signal corresponding to the amino group at 4.48 ppm, a quartet corresponding to ( $\text{CH}_2\text{CH}_3$ ) at 4.18 ppm, a singlet assigned to ( $\text{CH}_2$ ) at 3.97 ppm, and a triplet assigned to ( $\text{CH}_2\text{CH}_3$ ) at 1.27 ppm. This proves the structure **10** and rules out the possible formation of **12**. An attempt to cyclize the amino triazole **10** into the corresponding triazolothiadiazinone **12** by heating in refluxing pyridine was unsuccessful. When chloroacetic acid was used instead of its ester in the former reaction, the product was identified as the amino acid **11** which could be cyclized into triazolothiadiazinone **12** in boiling phosphoryl chloride (Scheme 4).

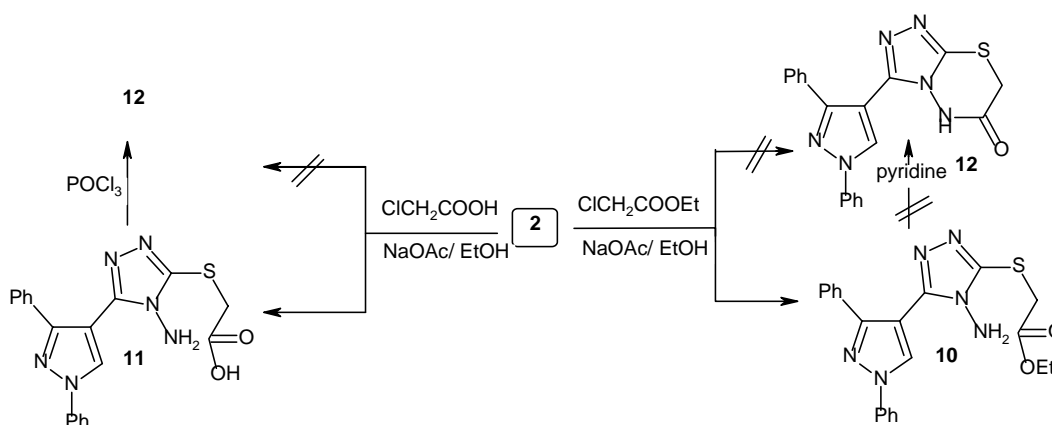

**Scheme 4.** Synthetic pathways for the preparation of compounds **10-12**.

Furthermore, treatment of the amino thione **2** with oxalyl chloride in dry benzene afforded the corresponding triazolothiadiazine-6,7-dione **13**. Also, its interaction with bromo diethylmalonate led to the formation of the thiadiazine-7-carboxylic acid ethyl ester **14**. Whereas, reaction of compound **2** with methyl-2-bromopropionate gave the corresponding S-substituted amino triazole **15** (Scheme 5).

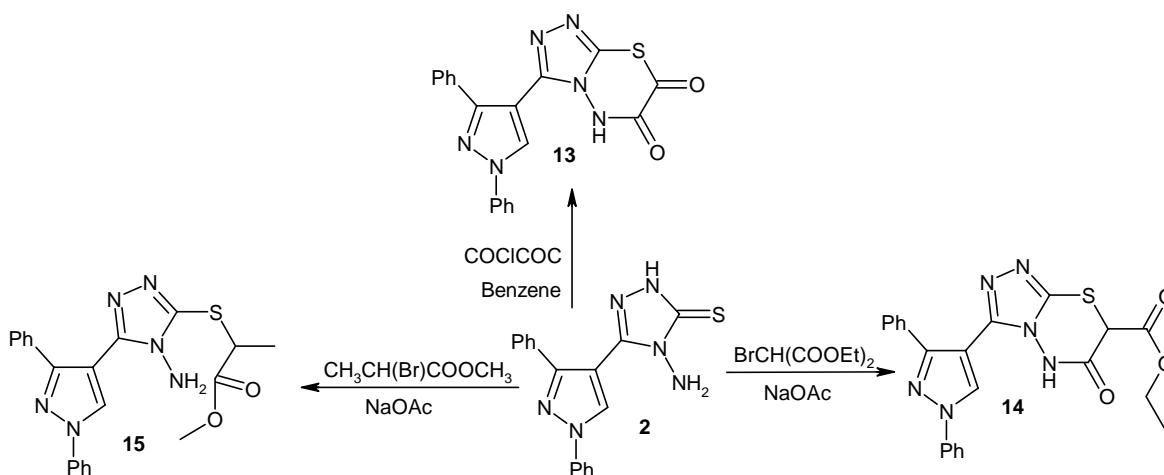

**Scheme 5.** Synthetic pathways for the preparation of compounds **13-15**.

A novel [1,2,4]triazolo[3,4-b][1,3,4]thiadiazepines **16-18** were prepared by the interaction of the triazolethione **2** with ethoxymethylenemalononitrile, ethyl ethoxymethylenecyanoacetate and benzoyl acetonitrile in boiling ethanol giving **16**, **17** and **18** respectively (Scheme 6).

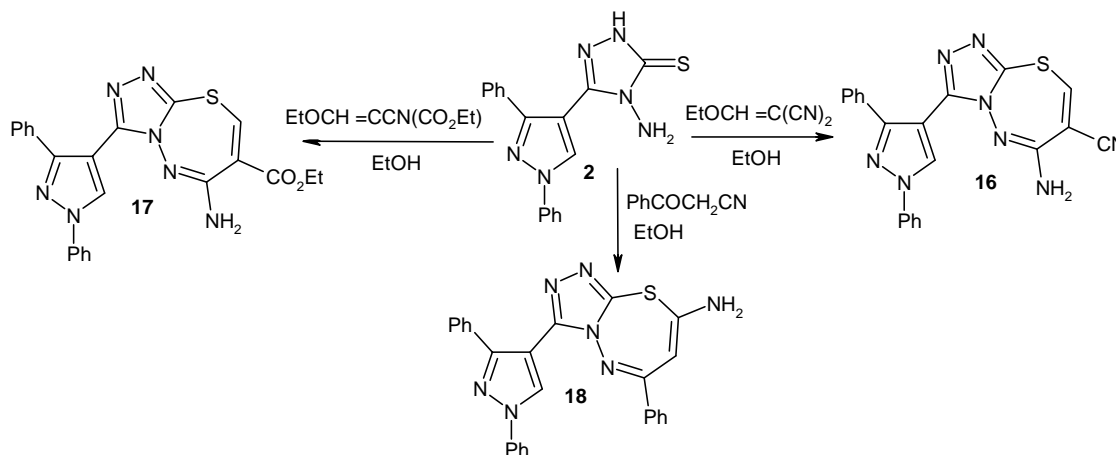

**Scheme 6.** Synthetic pathways for the preparation of compounds **16-18**.

Finally, all the trials to synthesize the triazolo thiadiazepines **19-21** by the reaction of the thione **2** with bifunctional reagents, pentane-2,4-dione, benzoyl acetone and 5-chloro-3-methyl pyrazole-4-carboxylaldehyde were unsuccessful (Scheme 7).

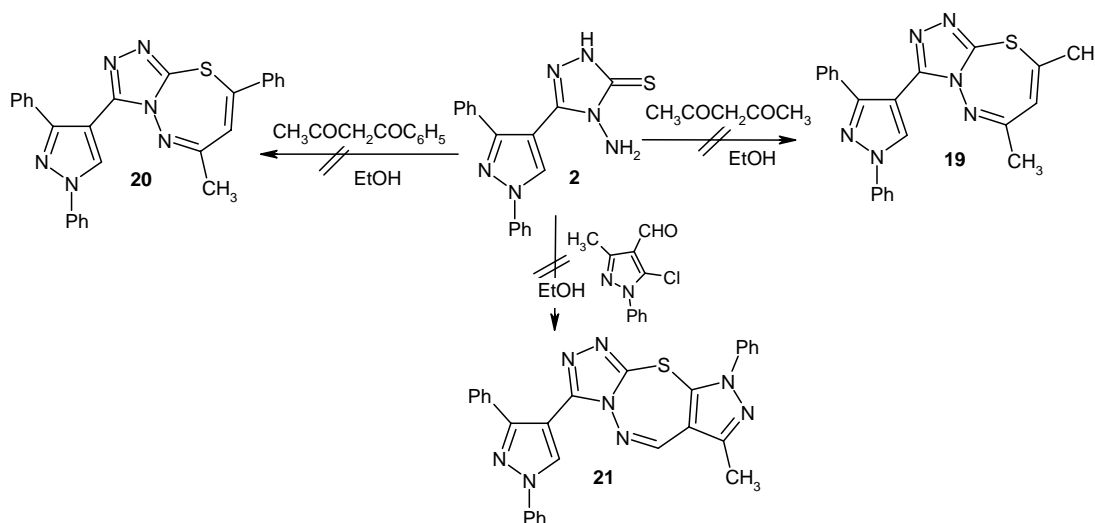

**Scheme 7.** Synthetic pathways for trials to preparation of thiadiazepines **19-21**.

## Experimental Section

**General Procedures.** Melting points are uncorrected and were measured on a Kofler melting point apparatus. IR spectra were recorded on a Shimadzu 470 IR-Spectrophotometer (KBr;  $\nu_{\max}$  in  $\text{cm}^{-1}$ ).  $^1\text{H}$  NMR and  $^{13}\text{C}$  NMR spectra were recorded on a Jeol LA 400 MHz FT NMR spectrometer and on a Varian EM 390, 90 MHz spectrometer (TMS as internal reference,  $\delta$  values in ppm). Mass spectra were obtained with a Jeol JMS-600 mass spectrometer. Elemental analyses (C, H and N) were carried out using a Perkin-Elmer 240 C Micro analyzer and sulfur analysis were obtained using oxygen flask method at the Chemistry Department (Microanalytical Laboratory), Assiut University.

**4-Amino-3-(1,3-diphenyl-1H-pyrazol-4-yl)-4,5-dihydro-[1,2,4]triazole-5(1H)-thione (2).** A mixture of oxadiazolethione **1**<sup>22</sup> (320 mg, 1 mmol) and hydrazine hydrate (3 mL, 60 mmol) in ethanol (10 mL) was heated under reflux for 6 h. After cooling, the solvent was removed *in vacuo* and the residue obtained was triturated with water. The solid product formed was filtered off and recrystallized from ethanol to give **2** as colorless crystals (297 mg, 89%), mp. 208-210 °C. IR (KBr) ( $\bar{\nu}$ ,  $\text{cm}^{-1}$ ) 3350, 3250 ( $\text{NH}_2$ ), 3150 (NH), 3030 (arom.CH), 1640 (C=N), 1210 (C=S);  $^1\text{H}$  NMR (DMSO- $d_6$ )  $\delta$  (ppm) 10.40 (s, 1H, NH), 8.96 (s, 1H, pyrazole CH), 7.93-7.80 (m, 4H, arH), 7.68-7.33 (m, 6H, arH), 5.63 (bs, 2H,  $\text{NH}_2$ ). Anal. calcd. for  $\text{C}_{17}\text{H}_{14}\text{N}_6\text{S}$  (334.40): C, 61.06; H, 4.22; N, 25.13; S, 9.59. Found: C, 60.87; H, 4.10; N, 25.00; S, 9.34.

**3-(1,3-Diphenyl-1H-pyrazol-4-yl)-5,6-dihydro-[1,2,4]triazolo[3,4-*b*][1,3,4] thiadiazol-6-one (3).** A mixture of **2** (122 mg, 0.36 mmol) and *N,N'*-carbonyldiimidazole (88 mg, 0.54 mmol) in dry dioxane (10 mL) was heated under reflux for 4 h. After cooling, the solvent was removed under reduced pressure and the solid product obtained was washed with water, filtered and recrystallized from ethanol to afford **3** as colorless crystals (102 mg, 78%), mp. 254-256 °C. IR (KBr) ( $\bar{\nu}$ ,  $\text{cm}^{-1}$ ) 3150 (NH), 3030 (arom.CH), 2950 (aliph CH), 1720 (C=O), 1610 (C=N).  $^1\text{H}$  NMR (DMSO- $d_6$ )  $\delta$  (ppm) 10.43 (s, 1H, NH), 9.08 (s, 1H, pyrazole CH), 8.03-7.73 (m, 4H, arH), 7.67-7.33 (m, 6H, arH); Anal. calcd. for  $\text{C}_{18}\text{H}_{12}\text{N}_6\text{OS}$  (360.40): C, 59.99; H, 3.36; N, 23.32; S, 8.90. Found: C, 59.78; H, 3.17; N, 23.15; S, 8.79.

**3-(1,3-Diphenyl-1H-pyrazol-4-yl)-5,6-dihydro-[1,2,4]triazolo[3,4-*b*][1,3,4] thiadiazole-6-thione (4).** To a solution of **2** (300 mg, 0.89 mmol) in ethanol (10 mL), KOH (1 g) and  $\text{CS}_2$  (2 mL) were added and the reaction mixture was refluxed for 2 h. The solvent was removed under reduced pressure, and then the residue was poured into an ice-water mixture with stirring. The solid product obtained was washed with water, filtered and recrystallized from ethanol to give **4** as colorless crystals (255 mg, 88%), mp. 198-200 °C. IR (KBr) ( $\bar{\nu}$ ,  $\text{cm}^{-1}$ ) 3100 (NH), 3050 (arom.CH), 1620 (C=N);  $^1\text{H}$  NMR (DMSO- $d_6$ )  $\delta$  (ppm) 11.40 (s, 1H, NH), 9.10 (s, 1H, pyrazole CH), 8.00-7.78 (m, 4H, arH), 7.68-7.35 (m, 6H, arH); Anal. calcd. for  $\text{C}_{18}\text{H}_{12}\text{N}_6\text{S}_2$  (376.46): C, 57.43; H, 3.21; N, 22.32; S, 17.03. Found: C, 57.68; H, 3.04; N, 22.13; S, 16.89.

**4-Amino-3-(1,3-diphenyl-1H-pyrazol-4-yl)-5-ethoxycarbonylsulfanyl[1,2,4]triazole (5).** A mixture of **2** (334 mg, 1 mmol) and ethyl chloroformate (108.5 mg, 1 mmol) in dry benzene (10 mL) was heated under reflux for 5 h. After cooling, the solvent was removed under reduced

pressure and the solid residue obtained was recrystallized from ethanol to yield **5** as colorless crystals (250 mg, 62%), mp.170-172 °C. IR (KBr) ( $\bar{\nu}$ ,  $\text{cm}^{-1}$ ) 3350, 3250 ( $\text{NH}_2$ ), 3030 (arom.CH), 2900 (aliph. CH), 1770 ( $\text{C}=\text{O}$ ), 1620 ( $\text{C}=\text{N}$ );  $^1\text{H}$  NMR ( $\text{CDCl}_3$ )  $\delta$  (ppm) 9.08 (s, 1H, pyrazole CH), 7.97-7.83 (m, 2H, arH), 7.70-7.50 (m, 8H, arH), 5.71 (bs, 2H,  $\text{NH}_2$ ), 4.38 (q,  $J = 6.7$  Hz, 2H,  $\text{CH}_2\text{CH}_3$ ), 1.30 (t,  $J = 6.7$  Hz, 3H,  $\text{CH}_2\text{CH}_3$ );  $^{13}\text{C}$  NMR ( $\text{CDCl}_3$ )  $\delta$  (ppm) 167.8 ( $\text{C}=\text{O}$ ), 165.7 (triazole-C-5), 151.4 (triazole-C-3), 150.9 (pyrazole-C-3), 118.7 (pyrazole-C-5), 106.2 (pyrazole-C-4), ar-C: [145.3 (C), 147.8 (C), 131.8 (2CH), 131.4 (2CH), 129.7 (2CH), 128.2 (2CH), 127.9 (2CH), 64.2 ( $-\text{OCH}_2\text{CH}_3$ ), 13.8 ( $-\text{OCH}_2\text{CH}_3$ ); Anal. calcd. for  $\text{C}_{20}\text{H}_{18}\text{N}_6\text{O}_2\text{S}$  (406.47): C, 59.10; H, 4.46; N, 20.68; S, 7.89. Found: C, 58.97; H, 4.34; N, 20.53; S, 7.71.

**General procedure for the synthesis of compounds (6a,b).** A mixture of **2** (334 mg, 1 mmol) and acetyl and/or benzoyl chloride (1 mmol) in dry dioxane (10 mL) was heated under reflux for 12 h. After cooling, the solvent was removed under reduced pressure and the residue obtained was triturated with ethanol and recrystallized from ethanol to afford **6a,b**.

**4-Acetylamino-3-(1,3-diphenyl-1H-pyrazol-4-yl)-4,5-dihydro-[1,2,4]triazole-5(1H)-thione (6a).** Colorless crystals (200 mg, 53%), mp.258-260 °C. IR (KBr) ( $\bar{\nu}$ ,  $\text{cm}^{-1}$ ) 3180 (NH), 3030 (arom.CH), 2910 (aliph. CH), 1700 ( $\text{C}=\text{O}$ ), 1620 ( $\text{C}=\text{N}$ ), 1310-1340 ( $\text{C}=\text{S}$ );  $^1\text{H}$  NMR ( $\text{DMSO-d}_6$ )  $\delta$  (ppm) 10.40 (s, 1H,  $\text{NHCO}$ ), 8.87 (s, 1H, NH), 8.58 (s, 1H, pyrazole CH), 7.90-7.73 (m, 4H, arH), 7.63-7.27 (m, 6H, arH), 1.97 (s, 3H,  $\text{COCH}_3$ ); Anal. calcd. for  $\text{C}_{19}\text{H}_{16}\text{N}_6\text{OS}$  (376.44): C, 60.62; H, 4.28; N, 22.33; S, 8.52. Found: C, 60.48; H, 4.12; N, 22.21 S, 8.36.

**4-Benzoylamino-3-(1,3-diphenyl-1H-pyrazol-4-yl)-4,5-dihydro-[1,2,4]triazole-5(1H)-thione (6b).** colorless crystals (250 mg, 65%), m.p.128-130 °C. IR (KBr) ( $\bar{\nu}$ ,  $\text{cm}^{-1}$ ) 3180 (NH), 3030 (arom.CH.), 2910 (aliph.CH), 1680 ( $\text{C}=\text{O}$ ), 1620 ( $\text{C}=\text{N}$ ), 1310-1340 ( $\text{C}=\text{S}$ );  $^1\text{H}$  NMR ( $\text{DMSO-d}_6$ )  $\delta$  (ppm)10.40 (s, 1H,  $\text{NHCO}$ ), 8.93 (s, 1H, NH), 8.75 (s, 1H, pyrazole CH), 7.97-7.67 (m, 8H, arH and NH), 7.57-7.40 (m, 8H, arH); Anal. calcd. for  $\text{C}_{24}\text{H}_{18}\text{N}_6\text{OS}$  (438.13): C, 65.74; H, 4.14; N, 19.17; S, 7.31. Found: C, 65.61; H, 4.02; N, 19.10; S, 7.22.

**General procedure for the synthesis of compounds (7a,b).**

**Method a.** A mixture of **6a,b** (1 mmol) and phosphoryl chloride (10 mL) was heated under reflux for 2 h. After removing the excess of phosphoryl chloride under reduced pressure, an ice-water mixture was added to the residue with vigorous stirring. The reaction mixture was neutralized with ammonium hydroxide and the solid precipitate formed was filtered and recrystallized from ethanol to give **7a,b**.

**Method b.** A mixture of **2** (334 mg, 1 mmol) and acetic acid (60 mg, 1 mmol) in phosphoryl chloride (10 mL) was heated under reflux for 2 h. After cooling, the solvent was removed under reduced pressure and an ice-water mixture was added to the residue with stirring. The reaction mixture was neutralized with ammonium hydroxide and the solid precipitate formed was filtered and recrystallized from ethanol to give **7a**. mp. and mixed mp. with a sample obtained by the above procedure are identical.

**3-(1,3-Diphenyl-1H-pyrazol-4-yl)-6-methyl-[1,2,4]triazolo[3,4-b][1,3,4]thiadiazole (7a).**

Colorless crystals (214 mg, 60 %) for method **a** and (294 mg, 82%) for method **b**, mp.178-180 °C. IR (KBr) ( $\bar{\nu}$ ,  $\text{cm}^{-1}$ ) 3030 (arom.CH.), 2910 (aliph. CH), 1620 ( $\text{C}=\text{N}$ );  $^1\text{H}$  NMR ( $\text{DMSO-d}_6$ )

$\delta$  (ppm) 8.97 (s, 1H, pyrazole CH), 8.00-7.73 (m, 4H, arH), 7.60-7.33 (m, 6H, arH), 2.71 (s, 3H, CH<sub>3</sub>); <sup>13</sup>C NMR (DMSO-d<sub>6</sub>)  $\delta$  (ppm) 166.5 (triazolothiadiazole-C-8), 157.9 (triazolothiadiazole-C-6), 150.3 (triazolothiadiazole-C-3), 139.8 (pyrazole-C-3), 118.3 (pyrazole-C-5), 106.4 (pyrazole-C-4), ar-C: [138.8 (C), 134.7 (C), 131.8 (2CH), 129.6 (2CH), 128.3 (CH), 128.2 (2CH), 127.9 (2CH), 126.8 (CH), 17.9 (-CH<sub>3</sub>); Anal. calcd. for C<sub>19</sub>H<sub>14</sub>N<sub>3</sub>S (358.10): C, 63.67; H, 3.94; N, 23.45; S, 8.95. Found: C, 63.42; H, 3.72; N, 23.14; S, 8.76.

**3-(1,3-Diphenyl-1H-pyrazol-4-yl)-6-phenyl-[1,2,4]triazolo[3,4-*b*][1,3,4]thiadiazole (7 b).** Yellowish orange crystals (250 mg, 57%), mp.208-210 °C. IR (KBr) ( $\bar{\nu}$ , cm<sup>-1</sup>) 3030 (arom.CH.), 2910 (aliph. CH), 1620 (C=N); <sup>1</sup>H NMR (DMSO-d<sub>6</sub>)  $\delta$  (ppm) 9.13 (s, 1H, pyrazole CH), 8.07-7.77 (m, 6H, arH), 7.63-7.77 (m, 9H, arH); Anal. calcd. for C<sub>24</sub>H<sub>16</sub>N<sub>6</sub>S (420.50): C, 68.55; H, 3.84; N, 19.99; S, 7.63. Found: C, 68.34; H, 3.72; N, 19.77; S, 7.47.

**6-Amino-3-(1,3-diphenyl-1H-pyrazol-4-yl)-7H-[1,2,4]triazolo[3,4-*b*][1,3,4] thiadiazine (8).** A mixture of **2** (334 mg, 1 mmol), chloroacetonitrile (75 mg, 1 mmol) and sodium acetate (400 mg, 4.9 mmol) in ethanol (10 mL) was heated under reflux for 6 h. After cooling, the solvent was removed under reduced pressure and the solid product formed was washed with water, the precipitate obtained was filtered and recrystallized from ethanol to give **8** as colorless crystals (336 mg, 90%), mp.178-180 °C. IR (KBr) ( $\bar{\nu}$ , cm<sup>-1</sup>) 3250, 3150 (NH<sub>2</sub>), 3030 (arom. CH.), 2950, 2900 (aliph. CH), 1640 (C=N); <sup>1</sup>H NMR (DMSO-d<sub>6</sub>)  $\delta$  (ppm) 9.10 (s, 1H, pyrazole CH), 8.03-7.80 (m, 4H, arH), 7.73-7.33 (m, 6H, arH), 6.17 (bs, 2H, NH<sub>2</sub>), 4.42 (s, 2H, CH<sub>2</sub>); Anal. calcd. for C<sub>24</sub>H<sub>16</sub>N<sub>6</sub>S (420.50): C, 68.55; H, 3.84; N, 19.99; S, 7.63. Found: C, 68.34; H, 3.72; N, 19.77; S, 7.47.

**General procedure for the synthesis of compounds (9a,b).** A mixture of **2** (334 mg, 1 mmol), sodium acetate (200 mg, 2.5 mmol) and  $\alpha$ -halo ketones (chloroacetone or  $\alpha$ -bromoacetophenone) (1 mmol) in absolute ethanol (10 mL) was refluxed for 2 h. After cooling, the solvent was removed under vacuum and the precipitate formed was filtered, washed with water and the solid product obtained was recrystallized from ethanol to give **9a,b**.

**3-(1,3-Diphenyl-1H-pyrazol-4-yl)-6-methyl-7H-[1,2,4]triazolo[3,4-*b*][1,3,4] thiadiazine (9a).** Yellow crystals (311 mg, 84%), mp.194-196 °C. IR (KBr) ( $\bar{\nu}$ , cm<sup>-1</sup>) 3030 (arom.CH), 2950 (aliph. CH), 1620 (C=N); <sup>1</sup>H NMR (DMSO-d<sub>6</sub>)  $\delta$  (ppm) 8.97 (s, 1H, pyrazole CH), 8.03-7.90 (m, 4H, arH), 7.73-7.37 (m, 6H, arH), 3.92 (s, 2H, CH<sub>2</sub>), 2.08 (s, 3H, CH<sub>3</sub>); Anal. calcd. for C<sub>20</sub>H<sub>16</sub>N<sub>6</sub>S (372.45): C, 64.50; H, 4.33; N, 22.56; S, 8.61. Found: C, 64.34; H, 4.18; N, 22.43; S, 8.47.

**3-(1,3-Diphenyl-1H-pyrazol-4-yl)-6-phenyl-7H-[1,2,4]triazolo[3,4-*b*][1,3,4] thiadiazine (9b).** Pale yellow crystals (378 mg, 87%), mp.165-167 °C. IR (KBr) ( $\bar{\nu}$ , cm<sup>-1</sup>) 3030 (arom.CH.), 2950 (aliph. CH), 1620 (C=N); <sup>1</sup>H NMR (DMSO-d<sub>6</sub>)  $\delta$  (ppm) 9.07 (s, 1H, pyrazole CH), 8.03-7.90 (m, 6H, arH), 7.70-7.23 (m, 9H, arH), 4.30 (s, 2H, CH<sub>2</sub>); <sup>13</sup>C NMR (DMSO-d<sub>6</sub>)  $\delta$  (ppm) 159.1 (triazolothiadiazine-C-9), 151.0 (triazolothiadiazine-C-6), 145.8 (triazolothiadiazine-C-3), 140.9 (pyrazole-C-3), 118.3 (pyrazole-C-5), 106.4 (pyrazole-C-4), ar-C: [138.9 (C), 132.2 (C), 130.6 (2CH), 129.6 (2CH), 128.2 (2CH), 127.6 (2CH), 127.0 (2CH), 22.8



(-CH<sub>3</sub>), 25.1 (-CH<sub>2</sub>); Anal. calcd. for C<sub>25</sub>H<sub>18</sub>N<sub>6</sub>S (434.53): C, 69.10; H, 4.18; N, 19.34; S, 7.38. Found: C, 68.93; H, 4.07; N, 19.21; S, 7.25.

**Ethyl [4-amino-3-(1,3-diphenyl-1H-pyrazol-4-yl)-4H-[1,2,4]triazol-5-ylthio]-acetate (10).** To a mixture of **2** (334 mg, 1 mmol) and sodium acetate (400 mg, 4.9 mmol) in ethanol (10 mL), ethyl chloroacetate (122 mg, 1 mmol) was added and the reaction mixture was heated under reflux for 8 h. After cooling, the solvent was removed under reduced pressure and the solid product formed was recrystallized from ethanol to yield **10** as white crystals (288 mg, 68%), m.p.172-174°C. IR (KBr) ( $\bar{\nu}$ , cm<sup>-1</sup>) 3250, 3150 (NH<sub>2</sub>), 3030 (arom.CH.), 2950, 2900 (aliph. CH), 1740 (ester-C=O), 1640 (C=N); <sup>1</sup>H NMR (DMSO-d<sub>6</sub>)  $\delta$  (ppm): 8.92 (s, 1H, pyrazole CH), 7.90-7.63 (m, 4H, arH), 7.57-7.17 (m, 6H, arH), 5.92 (bs, 2H, NH<sub>2</sub>), 4.10 (q, *J* = 6.7 Hz, 2H, CH<sub>2</sub>CH<sub>3</sub>), 4.05 (s, 2H, CH<sub>2</sub>), 1.20 (t, *J* = 6.7 Hz, 3H, CH<sub>2</sub>CH<sub>3</sub>); Anal. calcd. for C<sub>21</sub>H<sub>20</sub>N<sub>6</sub>O<sub>2</sub>S (420.50): C, 59.98; H, 4.79; N, 19.99; S, 7.63. Found: C, 59.79; H, 4.64; N, 19.83; S, 7.45.

**[4-Amino-5-(1,3-diphenyl-1H-pyrazol-4-yl)-4H-[1,2,4]triazol-5-ylthio]-acetic acid (11).** A mixture of **2** (334 mg, 1 mmol), sodium acetate (500 mg, 6.1 mmol) and chloroacetic acid (104 mg, 1.1 mmol) in ethanol (10 mL) was heated under reflux for 12 h. After cooling, the solvent was removed under reduced pressure, the residue was dissolved in water (50 mL) and the product was extracted with CH<sub>2</sub>Cl<sub>2</sub> (3 × 50 mL). The organic layer was washed with water and dried over Na<sub>2</sub>SO<sub>4</sub>. The solvent was removed under reduced pressure and the solid product was recrystallized from ethanol to give **11** as colorless crystals (163 mg, 42%), mp.163-65 °C. IR (KBr) ( $\bar{\nu}$ , cm<sup>-1</sup>) 3250, 3150 (NH<sub>2</sub>), 3030 (arom.CH), 2950, 2900 (aliph. CH), 1640 (C=N); <sup>1</sup>H NMR (DMSO-d<sub>6</sub>)  $\delta$  (ppm) 12.17 (sb, 1H, OH), 8.90 (s, 1H, pyrazole CH), 7.87-7.63 (m, 4H, arH), 7.53-7.20 (m, 6H, arH), 5.47 (bs, 2H, NH<sub>2</sub>), 4.03 (s, 2H, CH<sub>2</sub>); Anal. calcd. for C<sub>19</sub>H<sub>16</sub>N<sub>6</sub>O<sub>2</sub>S (392.44): C, 58.15; H, 4.11; N, 21.41; S, 8.17. Found: C, 58.04; H, 3.92; N, 21.34; S, 7.93.

**3-(1,3-Diphenyl-1H-pyrazol-4-yl)-5,7-dihydro-[1,2,4]triazolo[3,4-*b*][1,3,4]thiadiazin-6-one (12).** A mixture of **11** (392 mg, 1 mmol) and phosphoryl chloride (10 mL) was heated under reflux for 2 h. After cooling, the solvent was removed under reduced pressure and the solid residue formed was poured into ice-water and neutralized with ammonia solution. The precipitate obtained was filtered off and recrystallized from ethanol to give **12** as colorless crystals (180 mg, 48%), mp.180-182°C. IR (KBr) ( $\bar{\nu}$ , cm<sup>-1</sup>) 3350 (NH), 3030 (arom.CH.), 2900 (aliph. CH), 1700 (C=O), 1620 (C=N); <sup>1</sup>H NMR (DMSO-d<sub>6</sub>)  $\delta$  (ppm) 10.35 (s, 1H, NH), 8.90 (s, 1H, pyrazole CH), 7.93-7.63 (m, 4H, arH), 7.47-7.20 (m, 6H, arH), 4.07 (s, 2H, CH<sub>2</sub>); Anal. calcd. for C<sub>19</sub>H<sub>14</sub>N<sub>6</sub>OS (374.43): C, 60.95; H, 3.77; N, 22.75; S, 8.56. Found: C, 60.71; H, 3.60; N, 22.58; S, 8.47.

**3-(1,3-Diphenyl-1H-pyrazol-4-yl)-[1,2,4]triazolo[3,4-*b*][1,3,4]thiadiazine-6,7-dione (13).** A mixture of **2** (334 mg, 1 mmol) and oxalylchloride (126 mg, 1 mmol) in dry benzene (10 mL) was heated under reflux for 6 h. The solvent was removed under reduced pressure, the solid product formed was filtered and recrystallized from ethanol to afford **13** as yellow crystals (250 mg, 64%), mp. 290-292 °C. IR (KBr) ( $\bar{\nu}$ , cm<sup>-1</sup>) 3120 (NH), 3030 (arom.CH) 1720 (C=O), 1600 (C=N); <sup>1</sup>H NMR (DMSO-d<sub>6</sub>)  $\delta$  (ppm) 10.57 (s, 1H, NH), 7.58 (s, 1H, pyrazole CH), 7.73-7.33

(m, 4H, arH), 7.65-7.35 (m, 6H, arH); Anal. calcd. for C<sub>19</sub>H<sub>12</sub>N<sub>6</sub>O<sub>2</sub>S (388.40): C, 58.75; H, 3.11; N, 21.64; S, 8.26. Found: C, 58.61; H, 3.00; N, 21.52; S, 8.08.

**Ethyl 3-(1,3-diphenyl-1H-pyrazol-4-yl)-6-oxo-6,7-dihydro-5H-[1,2,4]triazolo[3,4-b][1,3,4]thiadiazine-7-carboxylate (14).** A mixture of **2** (334 mg, 1 mmol), sodium acetate (500 mg, 6.1 mmol) and bromo diethylmalonate (239 mg, 1 mmol) in ethanol (10 mL) was heated under reflux for 8 h. After cooling, the solvent was removed under reduced pressure, the residue was dissolved in water (50 mL) and the product was extracted with CH<sub>2</sub>Cl<sub>2</sub> (3 × 50 mL). The organic layer was washed with water and dried over Na<sub>2</sub>SO<sub>4</sub>. The solvent was removed under reduced pressure and the solid product was recrystallized from ethanol to give **14** as colorless crystals (276 mg, 62%), mp.116-118°C. IR (KBr) ( $\bar{\nu}$ , cm<sup>-1</sup>) 3150 (NH), 3030 (arom.CH.), 2950, 2900 (aliph. CH), 1740 (C=O), 1620 (C=N); <sup>1</sup>H NMR (CDCl<sub>3</sub>)  $\delta$  (ppm) 8.40 (s, 1H, pyrazole CH), 7.73-7.57 (m, 4H, arH), 7.45-7.00 (m, 6H, arH), 4.00 (q, *J* = 7.0 Hz, 2H, CH<sub>2</sub>CH<sub>3</sub>), 2.07 (s, 1H, CHCOOCH<sub>2</sub>CH<sub>3</sub>), 1.13 (t, *J* = 7.0 Hz, 3H, CH<sub>2</sub>CH<sub>3</sub>); Anal. calcd. for C<sub>21</sub>H<sub>20</sub>N<sub>6</sub>O<sub>2</sub>S (420.50): C, 59.98; H, 4.79; N, 19.99; S, 7.63. Found: C, 59.79; H, 4.64; N, 19.83; S, 7.45.

**2-[4-Amino-3-(1,3-diphenyl-1H-pyrazol-4-yl)-4H-[1,2,4]triazol-5-ylthio]-propionic acid methyl ester (15).** A mixture of **2** (334 mg, 1 mmol), sodium acetate (500 mg, 6.1 mmol) and methyl 2-bromopropionate (167 mg, 1 mmol) in ethanol (10 mL) was added and the reaction mixture was heated under reflux for 6 h. After cooling, the solvent was removed under reduced pressure and the product obtained was collected, recrystallized from ethanol to give **15** as grey crystals (284 mg, 68%), mp.153-155 °C. IR (KBr) ( $\bar{\nu}$ , cm<sup>-1</sup>) 3250, 3150 (NH<sub>2</sub>), 3040 (arom. CH), 2950, 2900 (aliph. CH), 1740 (C=O), 1640 (C=N); <sup>1</sup>H NMR (CDCl<sub>3</sub>)  $\delta$  (ppm) 8.35 (s, 1H, pyrazole CH), 7.90-7.73 (m, 4H, arH), 7.63-7.37 (m, 6H, arH), 4.83 (bs, 2H, NH<sub>2</sub>), 4.23 (q, *J* = 8.4 Hz, 1H, CH<sub>3</sub>COOCH<sub>2</sub>CH<sub>3</sub>), 3.70 (s, 3H, CH<sub>3</sub>COOCH<sub>2</sub>CH<sub>3</sub>), 1.63 (d, *J* = 7.4 Hz, 3H, CH<sub>3</sub>COOCH<sub>2</sub>CH<sub>3</sub>); Anal. calcd. for C<sub>21</sub>H<sub>20</sub>N<sub>6</sub>O<sub>2</sub>S (420.49): C, 59.98; H, 4.79; N, 19.99; S, 7.63. Found: C, 59.77; H, 4.62; N, 19.71; S, 7.48.

**6-Amino-3-(1,3-diphenyl-1H-pyrazol-4-yl)-[1,2,4]triazolo[3,4-b][1,3,4] thiadiazepine-7-carbonitrile (16).** A mixture of **2** (334 mg, 1 mmol) and ethoxymethylenemalononitrile (122 mg, 1 mmol) in absolute ethanol (10 ml) was heated under reflux for 6 h. After cooling, the solvent was removed under reduced pressure and the solid residue was filtered and recrystallized from ethanol to give **16** as fine crystals (300 mg, 73%), mp.210-212°C. IR (KBr) ( $\bar{\nu}$ , cm<sup>-1</sup>) 3280, 3150 (NH<sub>2</sub>), 3030 (arom. CH.), 1640 (C=N); <sup>1</sup>H NMR (DMSO-d<sub>6</sub>)  $\delta$  (ppm) 8.97 (s, 1H, pyrazole CH), 7.93-7.73 (m, 4H, arH), 7.73-7.30 (m, 9H, arH, NH<sub>2</sub> and triazepine CH); <sup>13</sup>C NMR (CDCl<sub>3</sub>)  $\delta$  (ppm) 165.7 (triazolothiadiazepine-C-6), 163.5 (triazolothiadiazepine-C-10), 155.5 (triazolothiadiazepine-C-3), 154.3 (triazolothiadiazepine-C-8), 106.2 (triazolothiadiazepine-C-7), 150.9 (pyrazole-C-3), 118.6 (pyrazole-C-5), 119.2 (-C≡N), 112.7 (pyrazole-C-4), ar-C: [144.5 (C), 138.8 (C), 131.8 (2CH), 131.2 (2CH), 129.7 (2CH), 128.2 (2CH), 127.9 (2CH)]; Anal. calcd. for C<sub>21</sub>H<sub>14</sub>N<sub>8</sub>S (410.46): C, 61.45; H, 3.44; N, 27.30; S, 7.81. Found: C, 61.32; H, 3.23; N, 27.14; S, 7.65.

**Ethyl 6-amino-3-(1,3-diphenyl-1H-pyrazol-4-yl)-[1,2,4]triazolo[3,4-b][1,3,4] thiadiazepine-7-carboxylate (17).** A mixture of **2** (334 mg, 1 mmol) and ethyl ethoxymethylenecyanoacetate

(169 mg, 1 mmol) in absolute ethanol (10 ml) was heated under reflux for 6 h. After cooling, the solvent was removed under reduced pressure and the solid residue was filtered and recrystallized from ethanol to yield **17** as golden flakes (280 mg, 61%), mp.190-192°C. IR (KBr) ( $\bar{\nu}$ ,  $\text{cm}^{-1}$ ) 3450, 3350, 3200 ( $\text{NH}_2$ ), 3030 (arom.CH), 2900 (aliph. CH), 1700 (C=O), 1620 (C=N);  $^1\text{H}$  NMR (DMSO- $d_6$ )  $\delta$  (ppm) 9.13 (s, 1H, pyrazole CH), 7.74-7.32 (m, 4H, arH), 7.57-7.40 (m, 9H, arH,  $\text{NH}_2$  and triazipine CH), 4.17 (q,  $J = 7.0$  Hz, 2H,  $\text{CH}_2\text{CH}_3$ ), 1.26 (t,  $J = 7.0$  Hz, 3H,  $\text{CH}_2\text{CH}_3$ ); Anal. calcd. for  $\text{C}_{23}\text{H}_{19}\text{N}_7\text{O}_2\text{S}$  (457.51): C, 60.38; H, 4.19; N, 21.43; S, 7.01. Found: C, 60.24; H, 4.06; N, 21.20; S, 6.88.

**8-Amino-3-(1,3-diphenyl-1H-pyrazol-4-yl)-6-phenyl-[1,2,4]triazolo[3,4-b][1,3,4]**

**thiadiazepine (18)**. A mixture of **2** (334 mg, 1 mmol) and benzoylacetonitrile (145 mg, 1 mmol) in absolute ethanol (10 ml) was heated under reflux for 8 h. After cooling, the solvent was removed under reduced pressure, the solid product obtained was filtered and recrystallized from ethanol to give **18** as buff crystals (300 mg, 65%), mp.200-202 °C. IR (KBr) ( $\bar{\nu}$ ,  $\text{cm}^{-1}$ ) 3250, 3150 ( $\text{NH}_2$ ), 3030 (arom.CH), 1640 (C=N);  $^1\text{H}$  NMR (DMSO- $d_6$ )  $\delta$  (ppm) 8.98 (s, 1H, pyrazole CH), 7.90-7.78 (m, 4H, arH), 7.70-7.50 (m, 4H, arH), 7.47-7.30 (m, 8H, arH and triazipine CH), 5.60 (bs, 2H,  $\text{NH}_2$ ); Anal. calcd. for  $\text{C}_{26}\text{H}_{19}\text{N}_7\text{S}$  (461.54): C, 67.66; H, 4.15; N, 21.24; S, 6.95. Found: C, 67.66; H, 4.15; N, 21.24; S, 6.95

## Pharmacological activity assessment and results

Compounds were tested for antiviral activity and cytotoxicity in various viral test systems, according to previously published procedures<sup>23,24</sup>. The results of in vitro evaluation are summarized in Tables 1-3. None of the compounds inhibited the cytopathicity induced by vesicular stomatitis virus, Coxsackie virus B4, respiratory syncytial virus, parainfluenza-3 virus, reovirus-1, Sindbis virus and Punta Toro virus, herpes simplex virus-1 (KOS) or herpes simplex virus-2 (G), and vaccinia virus at subtoxic concentrations in HeLa, Vero or E<sub>6</sub>SM cell cultures, respectively (Tables 1-3).

**Table 1.** Cytotoxicity and antiviral activity in HEL cell cultures

Compound	Minimum Cytotoxic concentration <sup>a</sup> (µg/ml)	Minimum inhibitory concentration <sup>b</sup> (µg/ml)				
		Herpes simplex virus-1 (KOS)	Herpes simplex virus-2(G)	Vaccinia virus	Vesicular Stomatitis Virus	Herpes simplex virus-1 TK (KOS)
1	≥16	>16	>16	>16	>16	>16
2	400	>80	>80	>80	>80	>80
3	80	>16	>16	>16	>16	>16
4	400	>80	>80	>80	>80	>80
5	80	>16	>16	>16	>16	>16
6a	400	>80	>80 (240)	240	400	>80
6b	80	>16	>16 (48)	>16	>16	>16
7a	80	>16	>16	>16	>16	>16
7b	16	>3.2	>3.2	>3.2	>3.2	>3.2
8	80	>16	>16	>16	>16	>16
9a	≥16	>16	>16	>16	>16	>16
9b	16	>3.2	>3.2	>3.2	>3.2	>3.2
10	400	>80	>80	>80	>80	>80
11	400	>80	>80	>80	>80	>80
12	80	>16	>16	>16	>16	>16
13	400	>80	80	>80	>80	>80
14	400	>80	>80	>80	>80	>80
16	400	>80	>80	>80	>80	>80
17	80	>16	>16	>16	>16	>16
18	400	>80	>80	>80	>80	>80
Brivudin	>400	0.384	80	80	>400	>400
Ribavirin	>400	>400	>400	400	48	>400
Acyclovir	400	0.384	0.384	>400	>400	48
Ganciclovir	>100	0.096	0.032	>100	>100	0.48

<sup>a</sup> Required to cause a microscopically dateable alteration of normal cell morphology.

<sup>b</sup> Required to reduce virus-induced cytopathogenicity by 50%.

**Table 2.** Cytotoxicity and antiviral activity in HeLa cell cultures

Compound	Minimum Cytotoxic concentration <sup>a</sup> ( $\mu\text{g/ml}$ )	Minimum inhibitory concentration <sup>b</sup> ( $\mu\text{g/ml}$ )		
		Vesicular Stomatitis Virus	Coxsackie virus B4	Respiratory Syncytial virus
1	80	>16	48	>16
2	80	>16	>16	>16
3	80	>16	48	>16
4	400	>80	>80	>80
5	400	>80	>80	>80
6a	400	>80	>80	>80
6b	80	>16	48	>16
7a	80	>16	>16	>16
7b	16	>3.2	>3.2	>3.2
8	80	>16	>16	>16
9a	16	>3.2	>3.2	>3.2
9b	16	>3.2	1.92	>3.2
10	80	>16	>16	>16
11	400	>80	>80	>80
12	80	>16	>16	>16
13	400	>80	48	>80
14	400	>80	>80	>80
16	$\geq 80$	>16	>16	>16
17	80	>16	>16	>16
18	80	>16	>16	>16
Brivudin	$\geq 400$	>400	>400	400
(S)-DHPA	>400	400	>400	>400
Ribavirin	>400	48	48	80

<sup>a</sup> Required to cause a microscopically dateable alteration of normal cell morphology.

<sup>b</sup> Required to reduce virus-induced cytopathogenicity by 50%.

**Table 3.** Cytotoxicity and antiviral activity in Vero cell cultures

Compound	Minimum Cytotoxic concentration <sup>a</sup> (µg/ml)	Minimum inhibitory concentration <sup>b</sup> (µg/ml)				
		Para-Influenza-3 virus	Reovirus-1	Sindbis virus	Coxsackie Virus B4	Punta Toro virus
1	80	>16	>16	>16	>16	>16
2	80	>16	>16	>16	>16	>16
3	400	>80	>80	>80	>80	>80
4	≥80	>80	>80	>80	>80	>80
5	≥80	>80	>80	>80	>80	>80
6a	≥400	>80	>80	>80	>80	>80
6b	80	>16	>16	>16	>16	>16
7a	16	>3.2	>3.2	>3.2	>3.2	>3.2
7b	≥16	>16	>16	>16	>16	>16
8	80	>16	>16	>16	>16	>16
9a	80	>16	>16	>16	>16	>16
9b	80	>16	>16	>16	>16	>16
10	≥16	>16	>16	>16	>16	>16
11	400	>80	>80	>80	>80	>80
12	80	>16	>16	>16	>16	>16
13	400	>80	>80	>80	>80	>80
14	80	>16	>16	>16	>16	>16
16	400	>16	>16	>16	80	>16
17	80	>16	>16	>16	>16	>16
18	400	>16	>16	>16	80	>16
Brivudin	>400	>400	>400	>400	>400	>400
(S)-DHPA	>400	>400	>400	>400	>400	>400
Ribavirin	>400	80	80	400	>400	80

<sup>a</sup> Required to cause a microscopically dateable alteration of normal cell morphology.

<sup>b</sup> Required to reduce virus-induced cytopathogenicity by 50 %.

## References

- Demirbas, N.; Demirbas, A.; Karaoglu, S. A.; Çelik, E. *ARKIVOC* **2005**, (i), 75.
- Kritsanida, M.; Mouroutsou, A.; Marakos, P.; Pouli, N.; Papakonstantinou Garoufalias, S.; Pannecouque, C.; Witvrouw, M.; De Clercq, E. *Il Farmaco* **2002**, 57, 253.

3. Ghorab, M. M.; El-Sharief, A. M. Sh.; Ammar, Y. A.; Mohamed, Sh. I. *Phosphorus, Sulfur, Silicon & Relat. Elem.* **2001**, *173*, 223.
4. Wang, Zhongyi; Shi, Haoxin; Shi, Haijian. *J. Heterocycl. Chem.* **2001**, *38*, 355.
5. Palaska, E.; Sahin, G.; Kelicen, P.; Durlu, N. T.; Altinok, G. *Farmaco* **2002**, *57*, 101.
6. Labanauskas, L.; Kalcas, V.; Udrenaite, E.; Gaidelis, P.; Brukstus, A.; Dauksas, V. *Pharmazie* **2001**, *56*, 617.
7. Foroumadi, A.; Mirzaei, M.; Shafiee, A. *Pharmazie* **2001**, *56*, 610.
8. Sun, Xiao-Wen; Zhang, Yan; Zhang, Zi-Yi; Wang Qin; Wang, Shu-Fang. *Indian J. Chem.* **1999**, *38B(3)*, 380.
9. Udupi, R. H.; Suresh, G. V.; Setty, S. R.; Bhat, A. R. *J. Indian Chem. Soc.* **2000**, *77*, 302.
10. Nizamuddin; Gupta, M.; Khan, M. H.; Srivastava, M. K. *J. Sci. Ind. Res.* **1999**, *58*, 538.
11. Invidiata, F. P.; Simoni, D.; Scintu, F.; Pinna, N. *Farmaco.* **1996**, *51*, 659.
12. Mullican, M. D.; Wilson, M. W.; Connor, D. T.; Kostlan, C.R.; Schrier, D. J.; Dyer, R. D. *J. Med. Chem.* **1993**, *36*, 1090.
13. Omar, F. A.; Mahfouz, N. M.; Rahman, M. A. *Eur. J. Med. Chem.* **1996**, *31*, 819.
14. Amir, M.; Oberoi, A.; Alam, S. *Indian. J. Chem.* **1999**, *38B*, 237.
15. Tozkoparan, B.; Gokhan, N.; Aktay, G.; Yesilada, E.; Ertan, M. *Eur. J. Med. Chem.* **2000**, *35*, 743.
16. Holla, B. S.; Poorjary, N. K.; Rao, S. B.; Shivananda, M. K. *Eur. J. Med. Chem.* **2002**, *37*, 511.
17. Holla, B. S.; Akberali, P. M.; Shivananda, M. K. *Il Farmaco* **2001**, *56*, 919.
18. Turan-Zitouni, G.; Kaplancikli, Z. A.; Erol, K.; Kiliç, F. S. *Il Farmaco* **1999**, *54* 218.
19. Holla, B. S.; Gonsalves, R.; Shenoy, S. *Il Farmaco* **1998**, *53*, 574.
20. Holla, B. S.; Sarojini, B.; Rao, S. B.; Akberali, P. M.; Kumari, N. S.; Shetty, V. *Il Farmaco* **2001**, *56*, 565.
21. Farghaly, A. A.; Vanelle, P.; El-Kashef, H. S. *Heterocycl. Commun* **2005**, *11* (3-4), 255.
22. Farghaly, A.; El-Kashef, H. *ARKIVOC* **2006** (x) xxx.
23. De Clercq, E.; Descamps, J.; Verhelst, G.; Walker, R.T.; Jones, A. S.; Torrence, P. F.; Shugar, D. *J. Infect. Dis.* **1980**, *141*, 563.
24. De Clercq, E. *Antimicrob. Agents Chemother.* **1985**, *28*, 84.